



OC3 COOKER (3-Oven Oil Fired Aga)

Installation Instructions

REMEMBER: when replacing a part on this appliance, use only spare parts that you can be assured conform to the safety and performance specification that we require. Do not use reconditioned or copy parts that have not been clearly authorised by Aga.

PLEASE READ THESE INSTRUCTIONS BEFORE INSTALLING THIS APPLIANCE

CE For use in GB and IE

04/08 EINS 514127

CONTENTS

SECTION	CONTENTS	PAGE
	CONSUMER PROTECTION	3
	HEALTH & SAFETY	3
SITE REQUIREMENTS	TECHNICAL DATA - AGA OC3	4 -5
	INTRODUCTION	5
	REGULATIONS	5
	LOCATION	5
	OIL PIPE LINE	6
	OIL STORAGE	6
	FLUE SYSTEM	7
	AIR SUPPLY	8
	ELECTRICAL SUPPLY	8
	WIRING DIAGRAM	9
INSTALLATION REQUIREMENTS	SITE LOCATION	10
	OVEN VENT & FLUE BREAK PIPE CONNECTION	10
COMMISSIONING INSTRUCTIONS	BURNER HOUSING TO BARREL ALIGNMENT	11
	ELECTRICAL CONNECTION	12
	OIL PUMP CONNECTION	12
	ELECTRICAL CHECK	13
	FIT PRESSURE GAUGE	13
	VENT OIL PUMP	13
	ADJUST OIL PRESSURE	13
	SET COMBUSTION AIR	14
	ANCILLARY CONTROLS CHECK	15
	OVERHEAT THERMOSTAT	15
	INSTRUCT THE USER	15

HEALTH & SAFETY

Consumer Protection

As responsible manufacturers we take care to make sure that our products are designed and constructed to meet the required safety standard when properly installed and used.

IMPORTANT NOTE: PLEASE READ THE ACCOMPANYING WARRANTY.

Any alteration that is not approved by Aga could invalidate the approval of the appliance, operation of the warranty and could affect your statutory rights.

Health & Safety

This appliance may contain some of the materials that are indicated. It is the Users/Installers responsibility to ensure that the necessary personal protective clothing is worn when handling where applicable, the pertinent parts that contain any of the listed materials that could be interpreted as being injurious to health and safety, see below for information.

Firebricks, Fuel beds, Artificial Fuels

When handling use disposable gloves.

Fire cement

When handling use disposable gloves.

Glues and Sealants

Exercise caution - if these are still in liquid form use face masks and disposable gloves.

Glass Yarn, Mineral Wool, Insulation Pads

May be harmful if inhaled. May be irritating to skin, eyes, nose and throat. When handling avoid contact with skin or eyes. Use disposable gloves, face masks and eye protection. After handling wash hands and other exposed parts. When disposing of the product, reduce dust with water spray, ensure that parts are securely wrapped.

Site requirements

TECHNICAL DATA - AGA OC3

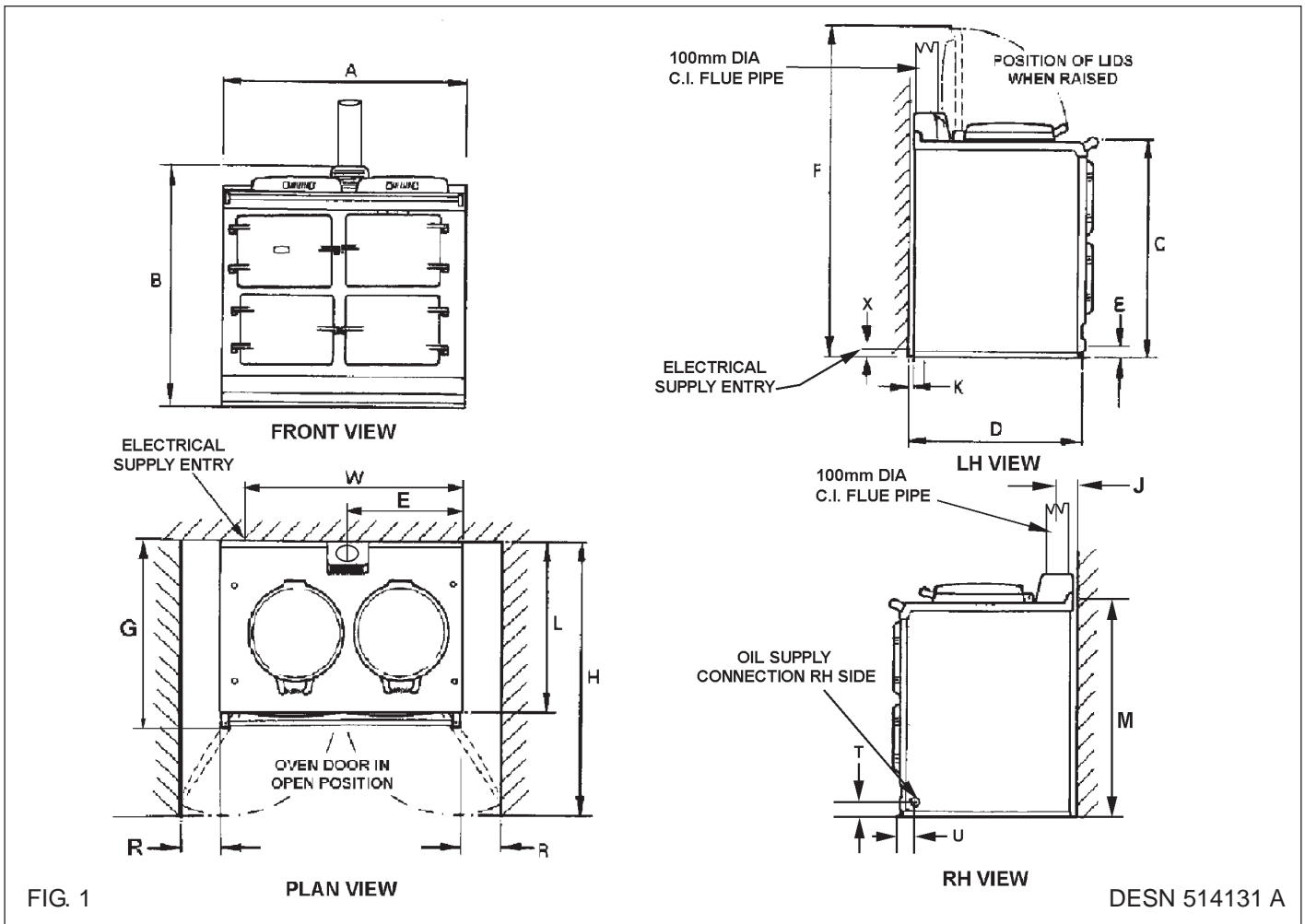

	A	B	C	D	E	F	G	H	J	K	L	M	R	T	U	W	X
mm	987	967	851	679	467	1450	756	1125	64	3	698	889	116	41	39	867	60

PLEASE NOTE: SIDE CLEARANCE DIMENSION R IS ALSO REQUIRED ON THE LH SIDE FOR THE BAKING OVEN DOOR.

COOKER DIMENSIONS

When surveying for a cooker installation the actual clearance for the 'body' of the appliance should be increased overall by 10mm beyond the figures quoted above. This allows safe margin to take into account the natural dimensional variations found in major castings. In particular the width across the appliance recess could be critical.

OIL CONNECTION - OC3

1/4" BSP supply pipe with 1/4" BSP to 10mm elbow fitting provided.

TECHNICAL DATA - CONTINUED

Oil Inlet	R1/4 (1/4" BSP Taper Ext)	Smoke 0 - 1
Electrical Supply	230V ~ 50Hz 3 amp Fused	Fuel - Kerosene Class C2
Flue Outlet	100 mm	Unpacked Weight of Appliance - 478 Kg
CO₂%	IN FLUE MANIFOLD 6.5 - 7.0 (COLD)	Firing Rate - 0.25 l/hr
CO (MAX)	62 ppm (Nominal rate)	Approximate Weekly Consumption -40 litres (8.8 gallons)
NOx (MAX)	106 ppm (Nominal rate)	

BURNER	
BURNER NOZZLE (US g/h)	0.30 @ 60° H (DANFOSS)
OIL PRESSURE Bar (psi)	5.2 (80)
OIL BURNING RATE cc/m (FIRING)	15
HEAT INPUT kW (FIRING)	9.5
OIL BURNING RATE (AVERAGE)	4.1 cc/min
OIL BURNING RATE (AVERAGE)	2.52 kW

INTRODUCTION

IMPORTANT:

- **This appliance must only be used with Kerosene Class C2 complying with BS. 2869.**
- **A fire valve MUST be fitted in the oil supply line.**
- **The supplied in line filter MUST be fitted.**

REGULATIONS

The installation of the appliance must be in accordance with the relevant standards. It should also be in accordance with the relevant Codes of Practice.

LOCATION

Appliance Hearth: The surface temperature of the floor below the appliance does not exceed 100°C. However this appliance must be installed on a solid floor or base of incombustible material which is capable of supporting the total weight.

The location chosen for the appliance must permit the installation and the provision of a satisfactory flue and an adequate air supply. The location must also provide adequate space for servicing and for air circulation around the appliance. See 'Installation of the Appliance'.

The space in which the appliance is to be fitted must have the following minimum dimensions:

Between wall and LH side of appliance - 10mm

Between wall and RH side of appliance - 10mm

SHOULD THE WALL PROJECT BEYOND THE FRONT OF THE APPLIANCE. WHEN IT MUST BE INCREASED TO 116mm.

Above the raised insulating cover - 60mm

In addition, adequate clearance must be available at the front of the appliance to enable it to be operated and serviced. Flue pipes and fittings must not be closer than 25mm to combustible materials and where passing through a combustible partition such as a ceiling or roof, must be enclosed in a non-combustible sleeve providing an air space of at least 25mm.

Spaces around flue pipes passing through walls or floors should be sealed against the passage of smoke and flame.

Where the cooker is to stand in a recess or against a wall which is to be tiled, in no circumstances should the tiles overlap the cooker top plate.

Site requirements

OIL PIPE LINE

SEE FIG. 2

The oil supply connection between the storage tank and the oil pipe should be run in copper or steel pipe with a minimum diameter of 10mm. Galvanised pipes and fittings should not be used. Annealed copper pipe is preferred with flare type manipulative fittings. Capillary fittings with soft solder should not be used. Steel pipes should be joined using taper threads.

All pipe work and fittings must be completely airtight. Only oil resistant compounds and PTFE tape should be used when making joints. Pipe work must be protected against damage whether fitted above or below ground.

The size and arrangement of pipe work will depend upon the distance and height of oil storage tank in relation to the oil pump inlet.

The oil line from the storage tank to the appliance must be fitted with a remote acting fire valve operating at 140°F (65°C), fitted with an appropriate length of capillary to enable the valve body to be located externally at the point where the oil line enters the building. The heat sensing phial of the fire valve MUST be fitted in an appropriate position to protect the building.

The paper element oil filter supplied with the appliance must be fitted on the oil pipe line and isolation valve must be fitted, as close to the cooker as possible in an accessible position. A fire valve must be installed to protect the property and the phial fitted in the clips provided.

A flexible pipe connection, is supplied to fit between the oil supply pipe and the oil pump for ease of burner removal.

OIL STORAGE

When positioning the tank, due consideration should be given to appropriate access for fuel delivery vehicles.

Positioning should comply with the relevant standards.

The tank should be complete with the following:

1. Sludge cock (steel tanks)
2. Outlet valve and filter
3. Contents indicator
4. Vent pipe
To prevent entry of water or fitted with return bend.
5. Fill pipe and screw cap (50mm black pipe)

The use of open lids to fill tanks is not recommended.

Steel Tanks - should be mounted on suitable supports. If of masonry, a damp proof membrane should be positioned between the tank and its supports to prevent the steel from rusting when in direct contact with water. Steel tanks should slope 20mm for each 1m run from the oil outlet towards the sludge cock (opposite end).

Plastic Oil Tanks - UV Stabilized, plastic tanks are a modern alternative to steel. These green tanks are protected against sunlight and do not need to stand on piers. They do however need to be supported over their entire base area. Ideally 50mm smooth faced garden slabs bedded down onto sand or a smooth concrete base.

The single tapped outlet makes them more suited to single pipe gravity feed.

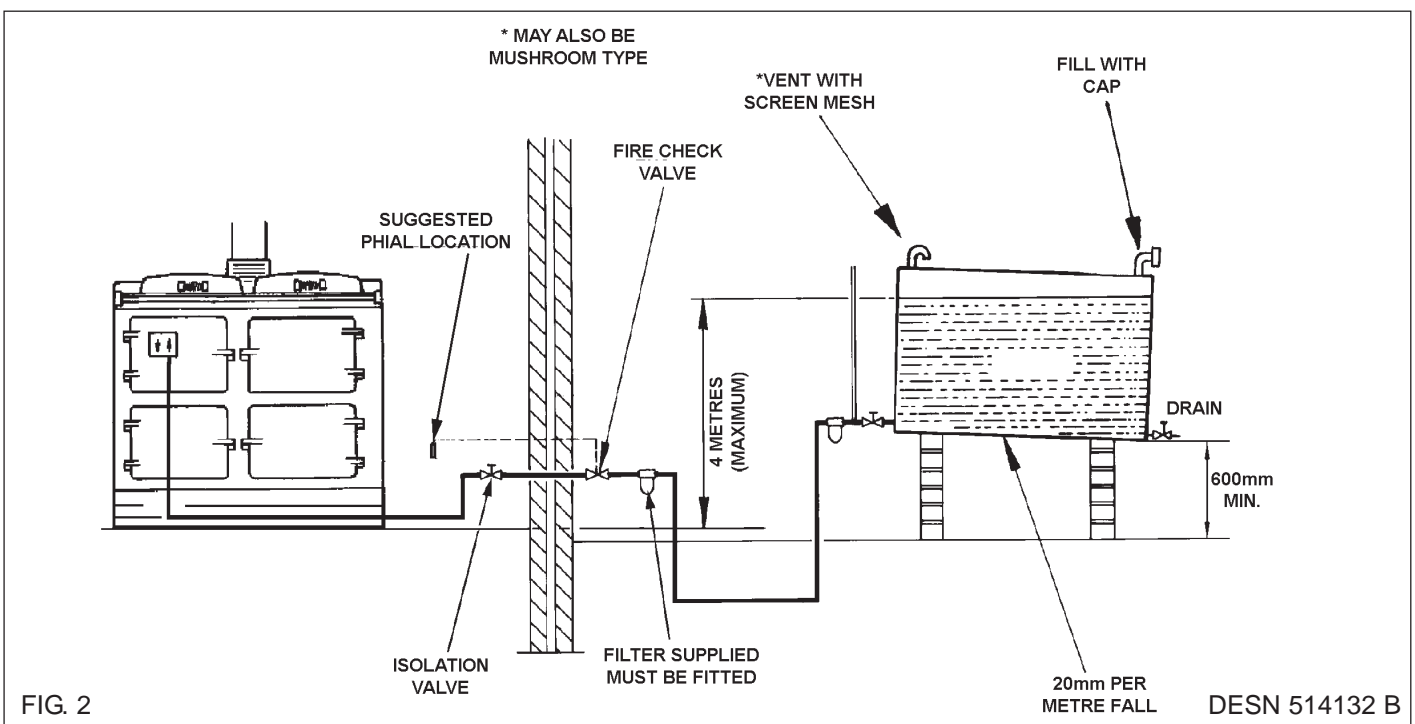

FIG. 2

DESN 514132 B

FLUE SYSTEM

The flue system must be installed to the regulations in force.

Information

Mean flue gas temperature 260°C.

The appliance requires a minimum negative chimney draught of 1.0mm W.G. (0.04" WG) with the burner on. Maximum chimney draught 3.7mm (0.15" WG). Draughts in excess of this will require a draught stabilizer fitted either in the chimney or flue pipe and in the same compartment.

Due to the range in flue gas temperature a brick chimney should be fitted with a suitable multi fuel stainless steel flexible liner. Factory built chimneys must comply with the relevant standards.

The cross-sectional area of the flue serving the appliance must not be less than the equivalent area of 100mm diameter flue pipe, and be at least 4.5m high.

The flue pipe must not be less than 100mm internal diameter. Flue pipes and fittings between the appliance and the chimney should be constructed from one of the following materials:

- a. Cast Iron
- b. Mild steel, acid resistant vitreous lined

Chimney Terminations

All chimneys should terminate above roof level, or with the relevant standards in force.

Chimney Cleaning

Ensure there are accessible airtight flue cleaning doors in order to obtain access to the complete chimney. Providing the appliance is operating correctly, an annual chimney flue cleaning will suffice, but if in doubt arrange for a half yearly clean.

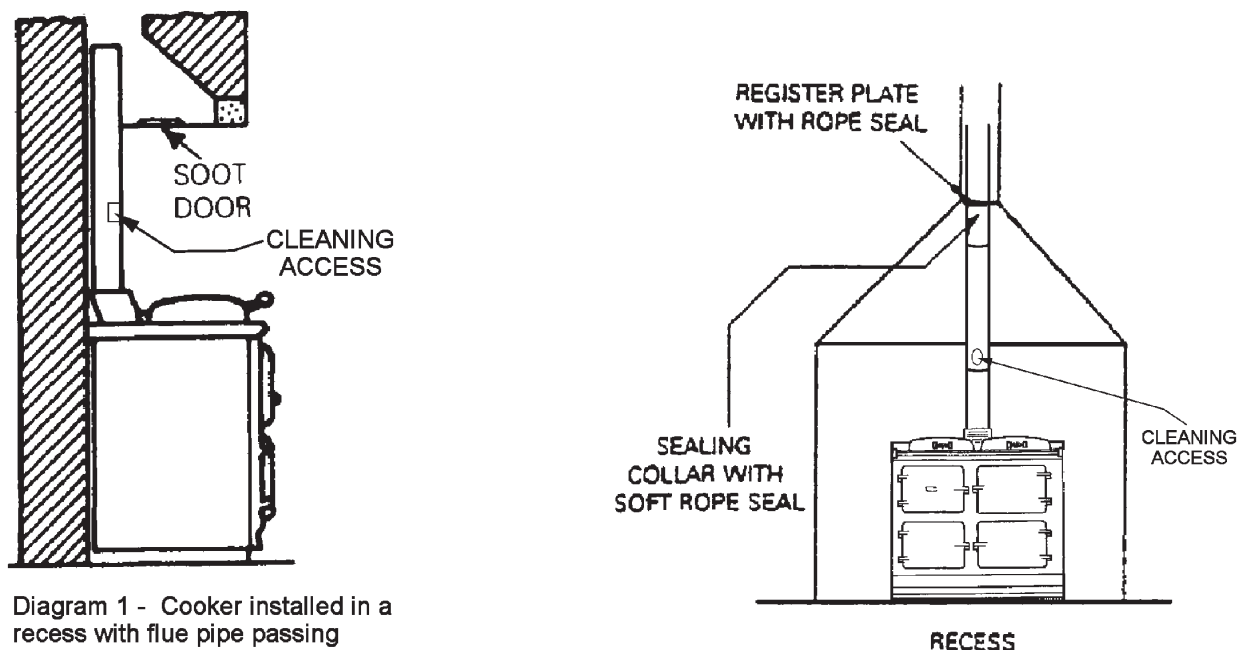

Diagram 1 - Cooker installed in a recess with flue pipe passing through the register plate into the throat of the chimney.

Site requirements

AIR SUPPLY

The appliance can only be installed in a room which meets the ventilation regulations in force. But, in any event the room must have a permanent vent of minimum free air area, see below.

MODEL	MIN. AIR REQUIREMENT
OC3	30 cm ²

Detailed recommendations are given in the relevant standards and codes of practice. The following notes are intended for general guidance.

1. Combustion and ventilation air supply to oil fired appliances has to comply with the relevant standards and codes of practice. The air supply requirement for oil fired appliances is 550m² per kW of maximum rated output above 5.0 kW.
2. The combustion air supply to open flued appliances should normally be provided at high level into a room where it will not cause discomfort by creating a cold draught across the floor.
3. If combustion air is supplied through an under floor duct the grilles at each end should be positioned in the vertical plane to reduce risk of blockage. Ducts should be sized so as to reduce resistance air flow.
4. Extract fan should be positioned as far away from the open flue as possible and should have a sufficient dedicated air supply. To undertake a test the oil fired appliance, should be set in operation and the doors and windows of the room containing it should be closed. The extract fan should then be run at its maximum setting. The oil fired appliance should then be run at its maximum setting. The oil fired appliance should be observed to operate satisfactorily both before and after the fan is switched on.
5. It is preferable for the air supply for an extract fan to be located where it can serve the fan without the air stream passing close to the oil fired appliance.
6. Oil fired appliances must not draw combustion air from a garage.

ELECTRICAL SUPPLY

Wiring external to the appliance must be installed in accordance with the relevant standards, wiring regulations and any local regulations which apply. The appliance is supplied for 220/230 Volt - 50 Hz and a fuse wiring of 3 amps.

The method of connection to the mains supply should facilitate complete electrical isolation of the appliance, by the use of a fused double pole switch having a contact separation of at least 3mm serving only the appliance. The point of connection to the mains should be readily accessible and adjacent to the appliance. The installation should be protected by a 30mA Residual Current Circuit Breaker (RCCB).

The minimum requirement for the power cable is that it should be a 3 core PVC sheathed flexible cord (85°C min) at least 0.75mm² (24 x 0.2mm) to the relevant standard.

WARNING: THIS APPLIANCE MUST BE EARTHED.

In the event of an electrical fault after installation of the appliance, preliminary electrical system checks must be carried out i.e. earth continuity, short circuit, polarity and resistance to earth.

For wiring instructions, see wiring diagram.

WIRING DIAGRAM

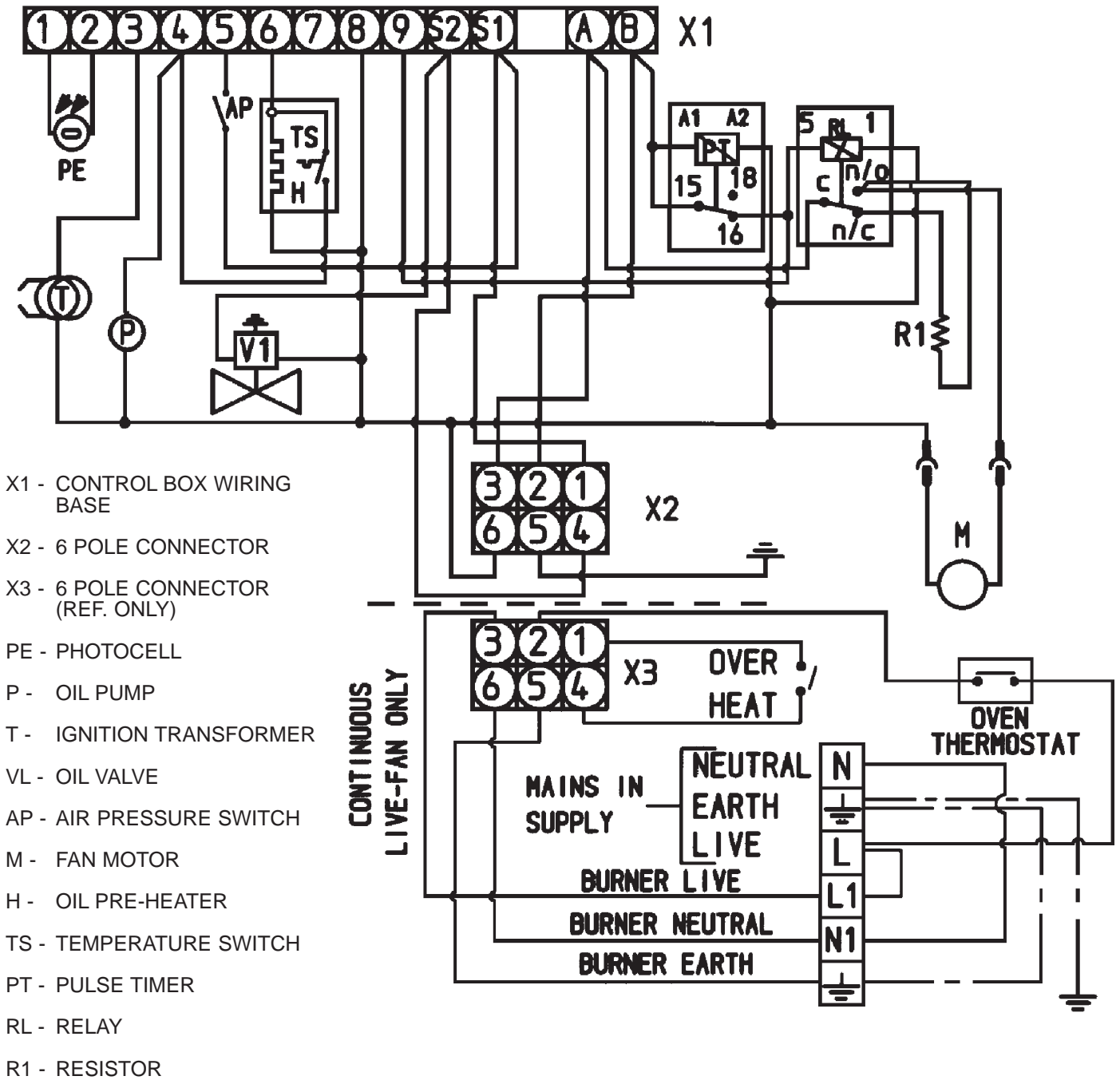

FIG. 5

Installation requirements

SITE LOCATION

1. Check that the hearth is level, then remove the appliance from its transit wooden pallet.
2. Connect and terminate the flue system in accordance with the regulations in force.

NOTE: SMOKE/SMELL EMITTED DURING INITIAL USAGE

During initial usage of operation of the cooker, smoke/smell may be emitted and is normal and not a fault with the appliance, it is therefore advisable to open doors and or windows to allow for ventilation.

OVEN VENT AND FLUE BREAK PIPE CONNECTION

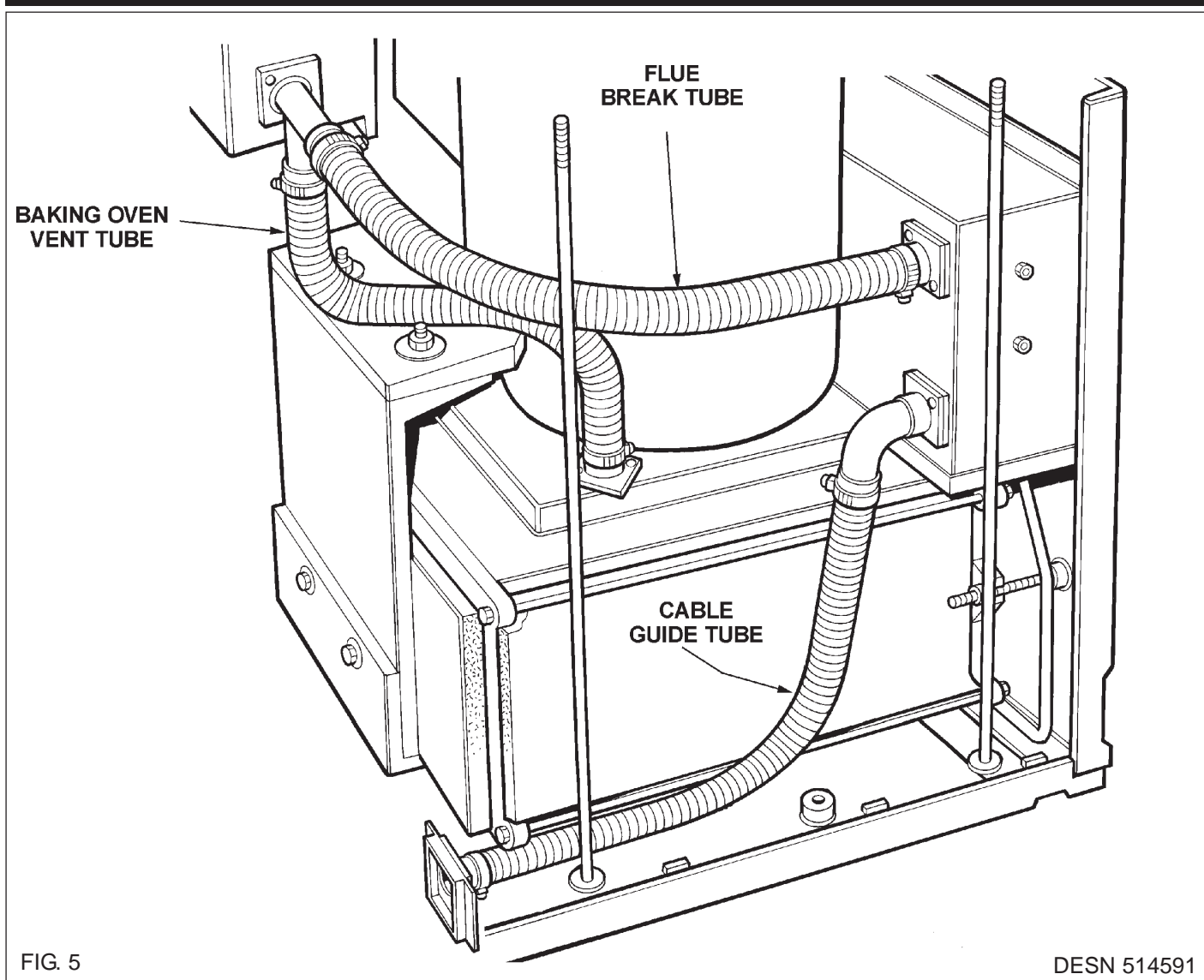

FIG. 5

DESN 514591

BURNER HOUSING TO BARREL ALIGNMENT

Prior to assembly fix (4) hex head screws (M6 x 25mm long) (marked A) to the burner housing, from the rear for fixing the burner.

To ensure correct fitting of burner, it is important that the 95 dia holes in the burner housing and fire barrel adaptor are in line with each other.

During assembly of the appliance, adjust the position of the burner housing by loosening the (2) screws 'B' and (2) nuts fixing the top flange burner housing to the front plate.

When the burner holes are in line, fit (4) countersunk head screws marked 'C' to fix the position of the burner housing to the fire barrel adaptor. **DO NOT** overtighten these screws 'C' to prevent distortion of the burner housing face, or to pull the fire barrel out of position.

On completion of the adjustment, tighten the screws fixing burner housing to front plate.

Ensure to seal the gap around the burner hole by corking rope between burner housing and fire barrel adaptor plate.

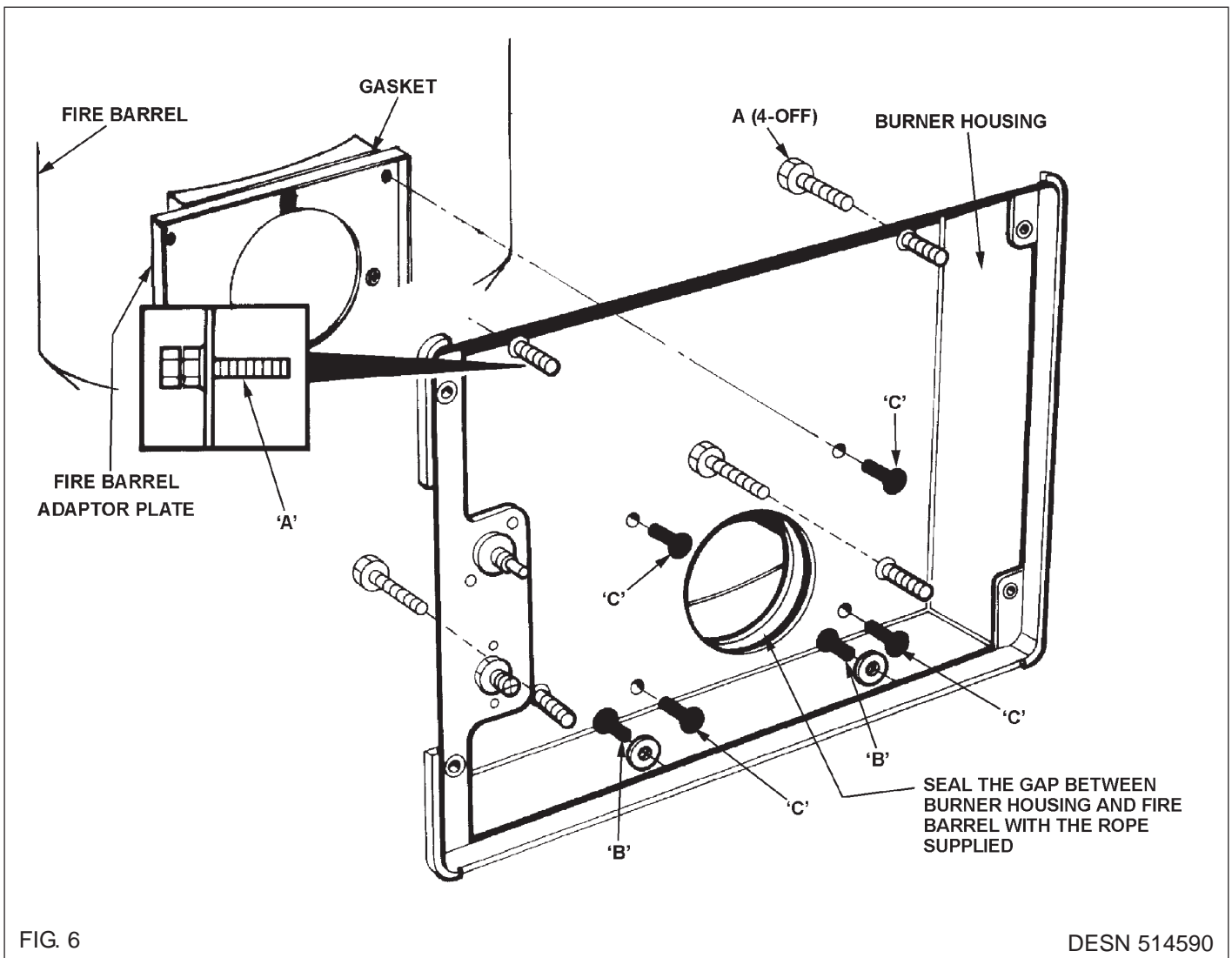

FIG. 6

DESN 514590

Commissioning Instructions

ELECTRICAL CONNECTION

SEE FIG. 7

1. Make electrical connections to terminal strip as wiring diagram. (See Fig. 7).

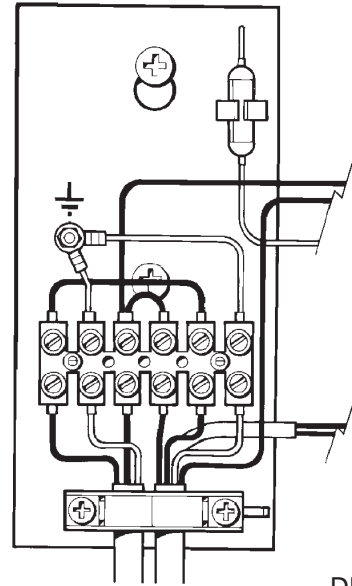

FIG. 7

DESN 514587

OIL PUMP CONNECTION

SEE FIG. 8

1. The sensing phial of the overheat stat should be located on the clip provided.
2. Connect the flexible hose to the outlet pipe from the oil feed.
3. Before connecting the flexible oil pipe to the pump inlet, open the stop valve slowly and run off some of the oil into a receptacle to establish an air free supply to the pump. Make the connection onto the oil pump tight and leave valve open.

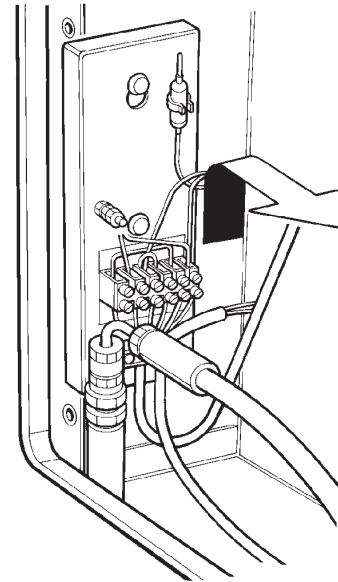

FIG. 8

DESN 514588

ELECTRICAL CHECK

Checks to ensure electrical safety should be carried out by a competent person.

FIT PRESSURE GAUGE

SEE FIG. 9

Remove the bleed screw from the manifold and fit an oil pressure gauge with R 1/8 connection to check the pump output pressure.

Switch on the Electricity

Set the cooker oven thermostat to position 4, wait 2 minutes for the pre-heater. The burner should run on pre-purge for 10 to 20 seconds, with the ignition spark energised. The oil solenoid valve should then open allowing the burner to fire.

Until all the air from the oil pump is flushed out there may be some flame instability resulting in the burner locking out.

This will be shown by the burner stopping and the illumination of the signal light in the reset button of the control box (See Fig. 10). In this event, wait at least one minute, then press the reset button to restart.

NOTE: This appliance is fitted with a pulse burner which has a four minute on and four minute off cycle.

VENT OIL PUMP

SEE FIG. 9

Whilst the burner is running, vent air from the pump by slackening the pressure gauge connection sufficient to allow air to bleed out. When bubble free oil seeps out retighten.

ADJUST OIL PRESSURE

SEE FIG. 9

After 15 minutes:

Whilst the burner is running, check the oil pressure on the gauge. Wait for 30 seconds after ignition, for the burner to establish the full firing rate.

If the pressure gauge is not indicating the correct reading then adjust the pressure by turning the pressure regulator clockwise to increase or anti-clockwise to decrease the pressure until the pressure gauge reads 5.2 bar (80 lbf/in²).

Switch off the burner, remove the pressure gauge and refit the bleed screw.

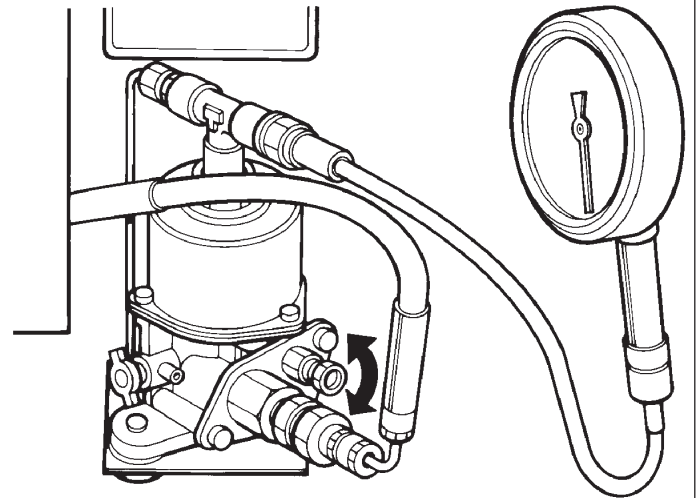

FIG. 9

DESN 513581

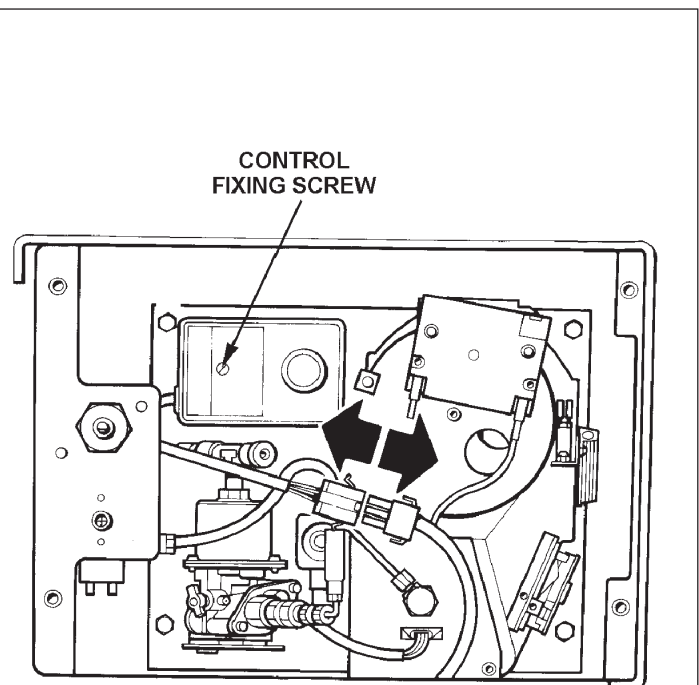

FIG. 10

DESN 514584

Commissioning Instructions

SET COMBUSTION AIR

SEE FIG. 11 & 12

The air control of the burner is factory pre-set, however small adjustments may be necessary to suit the site conditions.

Turn burner on.

After 15 minutes, remove screw. Insert the sensing end of a portable indicator to check the CO₂ (Carbon Dioxide) level. Adjust the burner air intake until a reading of 6.5 - 7.0 is recorded on the indicator.

Check Smoke

Remove the CO₂ sampling tube and using the same hole for flue sampling, insert the sensing end of a Baccarach Smoke Pump and check that the smoke does not exceed 0 - 1 on the scale. Replace the screw.

NOTE: Ensure that the sampling screw is fitted correctly as this forms part of the cooker combustion circuit.

Take care to fit shroud and avoid unnecessary enamel contact.

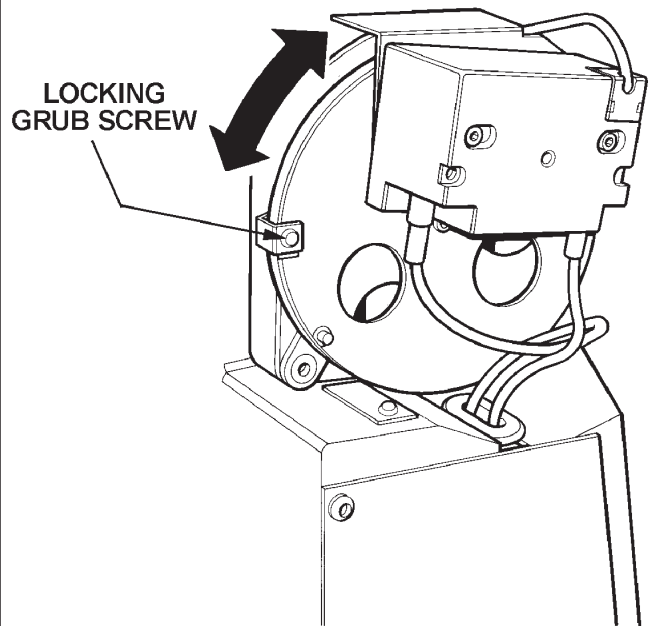

FIG. 11

DESN 514579

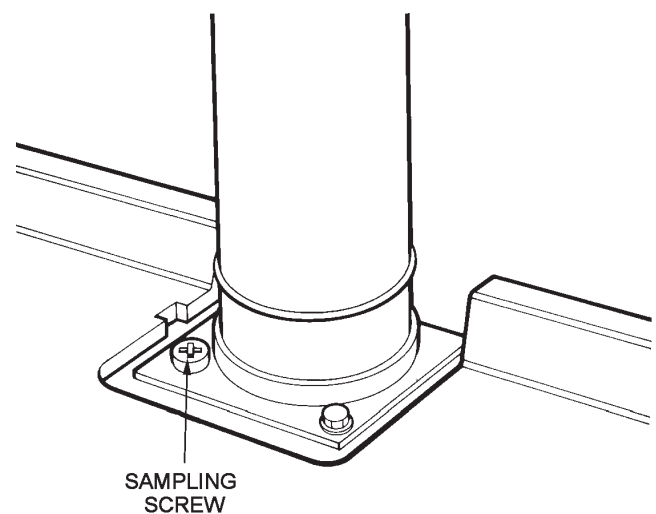

FIG. 12

DESN 513931

Commissioning Instructions

ANCILLARY CONTROLS CHECK

In the event of flame failure the control box should cut off the oil supply by closing the solenoid valve. The reset buttons will then be illuminated.

WAIT 1 MINUTE BEFORE RE-SETTING THE CONTROL BOX.

OVERHEAT THERMOSTAT

In the event of the appliance overheating, the burner is protected by a manual reset thermostat. When tripped, the thermostat will cut-off the oil supply causing the reset to be illuminated.

INSTRUCT THE USER

1. Advise the user that, for continued efficient and safe operation of the appliance, it is important that adequate servicing is carried out at regular 12 monthly intervals.
2. Hand the operating instructions to the user and demonstrate the correct operation of the appliance and system controls.
3. Leave the installation and servicing instructions with the user.

**For further advice or information contact
your local Aga Specialist**

With Aga's policy of continuous product improvement, the Company reserves the right to change specifications and make modifications to the appliance described and illustrated at any time



Manufactured by
Aga
Station Road
Ketley Telford
Shropshire TF1 5AQ
England

www.aga-web.co.uk
www.agacookshop.co.uk
www.agalinks.com