



# **Aga Gas Fired Cooker Models GC and GE with AIMS**

## *Installation Instructions*

REMEMBER: when replacing a part on this appliance, use only spare parts that you can be assured conform to the safety and performance specification that we require. Do not use reconditioned or copy parts that have not been clearly authorised by AGA.

**PLEASE READ THESE INSTRUCTIONS BEFORE INSTALLING THIS APPLIANCE**

 **For use in GB and IE**

12/13 EINS 515930

# CONTENTS

| <b>SECTION</b>                    | <b>PAGE</b> |
|-----------------------------------|-------------|
| HEALTH AND SAFETY                 | 3           |
| INSTALLATION                      | 4           |
| TECHNICAL DATA GC & GE AIMS       | 5 - 6       |
| LOCATION                          | 7           |
| FLUE SYSTEM                       | 7           |
| INSTALLATION PIPES                | 7           |
| AIR SUPPLY                        | 7           |
| ELECTRICAL                        | 8           |
| BURNER ASSEMBLY - AIMS CONTROL    | 9           |
| WIRING DIAGRAM                    | 9           |
| ASSEMBLY OF BURNER - AIMS CONTROL | 10          |
| OVEN THERMOCOUPLE                 | 10          |
| TO TEST THE AIMS CONTROL HANDSET  | 11          |
| COMMISSIONING                     | 12 - 13     |
| INSTRUCTIONS                      | 13          |
| BURNER CONTROLS                   | 14          |

## HEALTH & SAFETY

### **Consumer Protection**

As responsible manufacturers we take care to make sure that our products are designed and constructed to meet the required safety standards when properly installed and used.

This appliance is not intended for use by persons (including children) with reduced physical, sensory or mental capabilities, or lack of experience and knowledge, unless they have been given supervision or instruction concerning the use of the appliance by a person responsible for their safety.

Children should be supervised to ensure that they do not play with the appliance.

### **IMPORTANT NOTICE: PLEASE READ THE ACCOMPANYING WARRANTY.**

Any alteration that is not approved by AGA could invalidate the approval of the appliance, operation of the warranty and could affect your statutory rights.

### **Important**

This appliance may contain some of the materials that are indicated. It is the Users/Installers responsibility to ensure that the necessary personal protective clothing is worn when handling, where applicable, the pertinent parts that contain any of the listed materials that could be interpreted as being injurious to health and safety, see below for information.

**Firebricks, Fuel Beds, Artificial Fuels** - when handling use disposable gloves.

**Fire Cement** - when handling use disposable gloves.

**Glues and Sealants** - exercise caution, if these are still in liquid form use face mask and disposable gloves.

**Glass Yarn, Mineral Wool, Insulation Pads, Ceramic Fibre, Kerosene Oil** - may be harmful if inhaled, may be irritating to skin, eyes, nose and throat. When handling avoid inhaling and contact with skin or eyes. Use disposable gloves, face-masks and eye protection. After handling wash hands and other exposed parts. When disposing of the product, reduce dust with water spray, ensure that parts are securely wrapped.

# INSTALLATION

With specific exceptions, the installing of any type of AGA Cooker is the subject to the respective directions contained in current issue of The Building Regulations. In addition, Planning Permission may need to be obtained, which should be applied for separately. The complete range of AGA cookers are suitable for Natural Gas or Propane gases only and cannot be used on any other gas.

The complete cooker is floor-mounted and the space in which the appliance is to be fitted must have the following minimum dimensions:-

A minimum clearance of 60mm is required above the raised insulating cover handle.

**Side Clearances:** A 3mm gap is required each side between the cooker top plate and adjoining work surfaces that maybe fitted, this is to allow for the safe removal of the top plate, should this be required at a later date.

Where cookers are fitted against side walls a 116mm clearance is required at the right hand side for oven doors access. (A further 116mm is necessary, if a left hand side gas connection is required.

If the AGA is to be installed in a brick recess, then the minimum clearance should be increased by at least 10mm either side, to allow for the walls not being square and also for the natural dimensional variations found in the castings.

In addition a minimum clearance of 1000mm must be available at the front of the cooker to enable the cooker to be serviced.

The initial length of flue pipe from the appliance flue socket should be vertical for at least 600mm. In any event the minimum flue length must not be less than 3m.

Flue pipes and fittings must not be closer than 25mm to combustible materials and where passing through a combustible partition such as a ceiling or roof, must be enclosed in non-combustible sleeve providing a connector space of at least 25mm.

Spaces around flue pipes passing through walls or floors should be sealed against the passage of smoke and flame.

**NOTE:** AGA GAS FIRED COOKERS ARE DELIVERED EX-WORKS UNASSEMBLED. ASSEMBLY IS UNDERTAKEN ON SITE BY THE AUTHORISED AGA DISTRIBUTOR.

## **Cooker Base or Hearth**

It is essential that the base or hearth on which the cooker stands should be level and be capable of supporting the total weight of the respective cooker.

Models GC - 406kg, GE - 584kg

The top of the hearth must be of non-combustible material thickness of 12mm.

The wall behind the cooker must be of non-combustible material for a minimum thickness of 25mm.

## **Tiling**

When the cooker is to stand in a recess, or against a wall which is to be tiled, in no circumstances should the tiles overlap the cooker top plate.

## **Installation Requirements**

The installation of the cooker must be in accordance with the relevant requirements of the Gas Safety Regulations, Building Regulations and the bylaws of the local Water Undertaking.

It should be in accordance also with any relevant requirements of the Gas Region and Local Authority.

In your own interest, and that of safety to comply with the law, all gas appliances should be installed by a competent person, in accordance with the relative regulations. Failure to install appliances correctly could lead to prosecution.

On completion, test the gas installation for soundness.

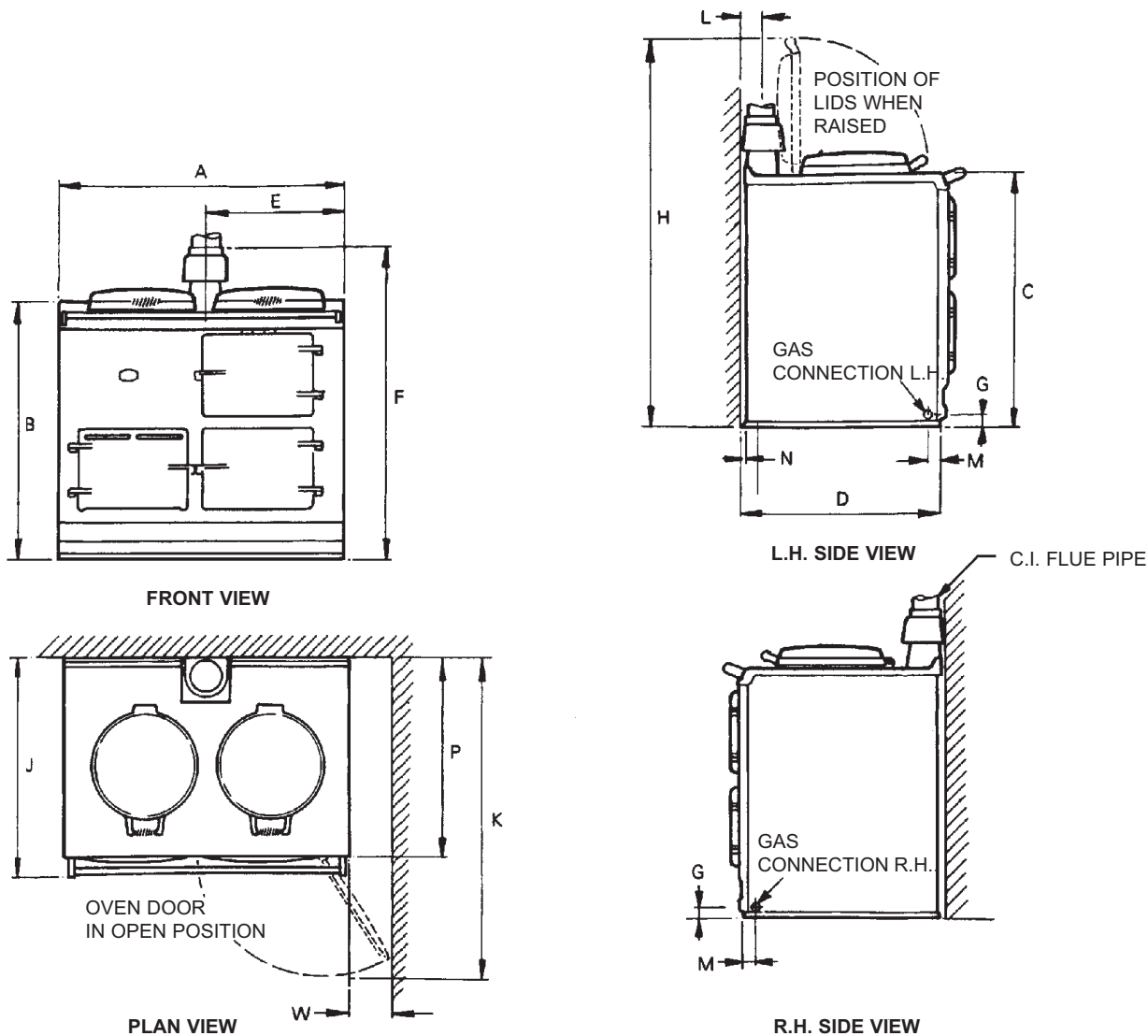

Fig. 1

DESN 515471

|    | A   | B   | C   | D   | E   | F    | G  | H    | J   | K    | L  | M  | N | P   | W   |
|----|-----|-----|-----|-----|-----|------|----|------|-----|------|----|----|---|-----|-----|
| mm | 987 | 889 | 851 | 679 | 467 | 1035 | 41 | 1330 | 756 | 1125 | 73 | 39 | 3 | 698 | 116 |

## TECHNICAL DATA

### AGA GC & GE COOKER (AIMS)

#### NATURAL G20

|                                    |                   |
|------------------------------------|-------------------|
| MAXIMUM HEAT INPUT                 | 4.4 kW            |
| Thermostat Bypass Size             | 110               |
| Main Burner Injector               | 400               |
| Pilot Injector                     | 7218              |
| Inlet Pressure (EU COUNTRIES ONLY) | 20mbar            |
| Burner Pressure                    | 10 mbar (4" w.g.) |

#### PROPANE G31

|                                    |                   |
|------------------------------------|-------------------|
| MAXIMUM HEAT INPUT                 | 5kW (357g/h)      |
| Thermostat Bypass Size             | 65                |
| Main Burner Injector               | 170               |
| Pilot Injector                     | 4209              |
| Inlet Pressure (EU COUNTRIES ONLY) | 37mbar            |
| Burner Pressure                    | 25mbar (10" w.g.) |

ELECTRICAL SUPPLY: 230V 50Hz 3A FUSED

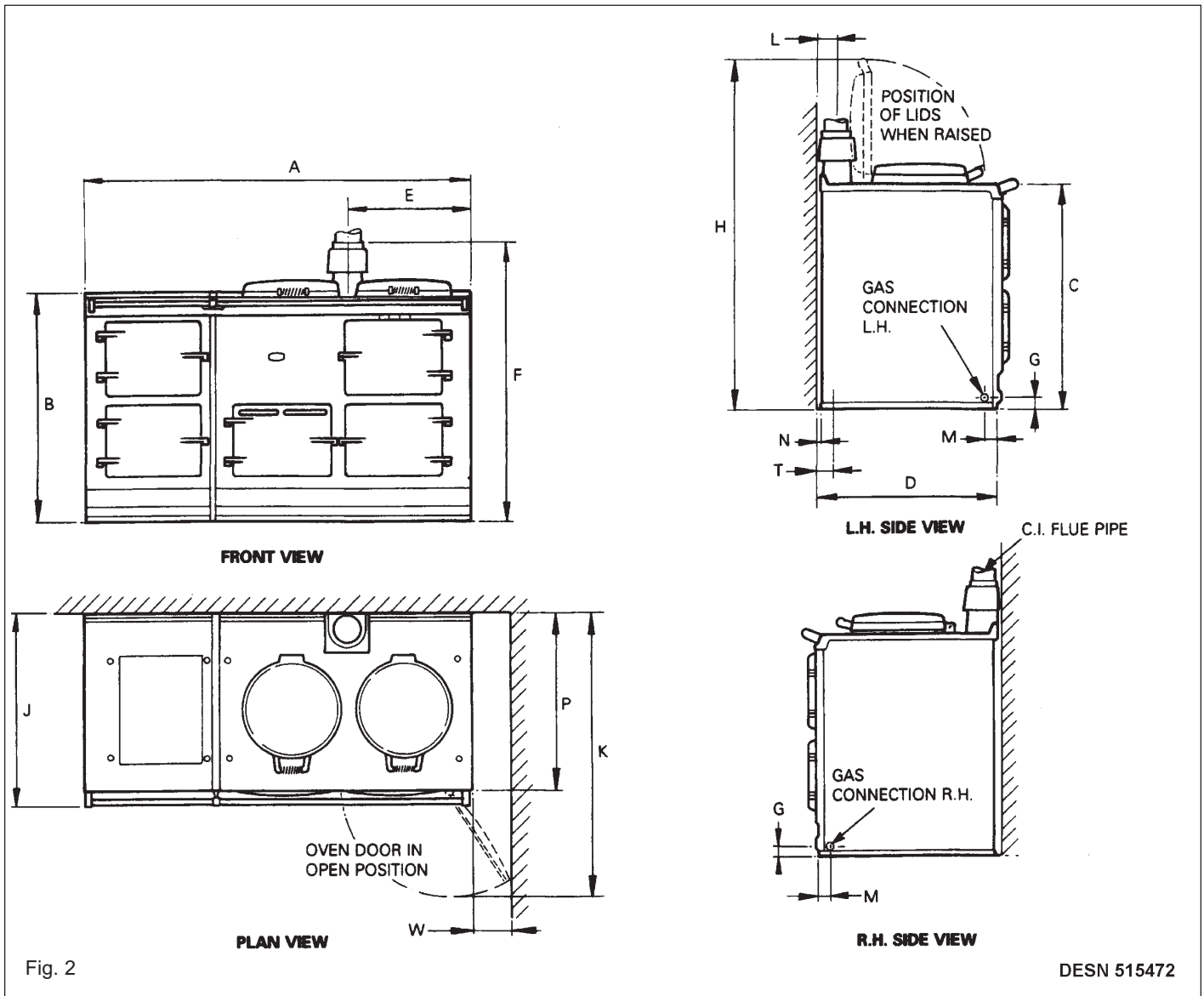

|    | A    | B   | C   | D   | E   | F    | G  | H    | J   | K    | L  | M  | N | P   | W   |
|----|------|-----|-----|-----|-----|------|----|------|-----|------|----|----|---|-----|-----|
| mm | 1487 | 889 | 851 | 679 | 467 | 1035 | 41 | 1330 | 756 | 1125 | 73 | 39 | 3 | 698 | 116 |

## TECHNICAL DATA

| <b>AGA GC &amp; GE COOKER (AIMS)</b>   |                   |
|--|-------------------|
| <b>NATURAL G20</b>                     |                   |
| MAXIMUM HEAT INPUT                     | 4.4 kW            |
| Thermostat Bypass Size                 | 110               |
| Main Burner Injector                   | 400               |
| Pilot Injector                         | 7218              |
| Inlet Pressure (EU COUNTRIES ONLY)     | 20mbar            |
| Burner Pressure                        | 10 mbar (4" w.g.) |
| <b>PROPANE G31</b>                     |                   |
| MAXIMUM HEAT INPUT                     | 5kW (357g/h)      |
| Thermostat Bypass Size                 | 65                |
| Main Burner Injector                   | 170               |
| Pilot Injector                         | 4209              |
| Inlet Pressure (EU COUNTRIES ONLY)     | 37mbar            |
| Burner Pressure                        | 25mbar (10" w.g.) |
| ELECTRICAL SUPPLY: 230V 50 Hz 3A FUSED |                   |

## LOCATION

The location chosen for the appliance must permit the provision of a satisfactory flue and an adequate air supply. The location must also provide adequate space for servicing and air circulation around the cooker

## FLUE SYSTEM

The following notes are intended to give general guidance:-

The initial length of flue pipe from the appliance flue socket should be vertical for at least 600mm. Should 600mm prove impractical then a shorter length of initial vertical flue may be used, subject to flue draught tests proving satisfactory.

In any event, the minimum length must not be less than 3m.

The cross-sectional area of the flue serving the cooker must not be less than the area of the flue outlet of the cooker. If the flue pipe is to be used it must not be less than 100mm internal diameter.

Flue pipes and fittings should be constructed from one of the following materials:-

- a) Cement
- b) Aluminium or stainless steel
- c) Cast iron, mild steel, acid resistant vitreous enamel lined

If a chimney is to be used, it preferably should be one that is composed of or lined with a non-porous acid resistant material. (Chimneys lined with salt glazed earthenware pipes are acceptable, if the pipes comply with the regulations in force). A flue pipe constructed from one of the materials in (a) to (c) above, should form the initial connection to lined chimneys.

Where a chimney is to be used which is not composed of or lined with a non-porous acid resistant material it should be lined with a stainless steel flexible flue liner. The internal diameter of the liner must not be less than 100mm and the number of joints must be kept to a minimum. If the flue liner is not connected directly to the appliance draught diverter a flue pipe which is constructed from one of the materials in (a) to (c) above should form the connection between the draught diverter and flue liner.

Before connecting the appliance to or inserting a liner into, a flue that has been previously used, the flue must be thoroughly swept clean of any soot and loose material. If a baffle is fitted in the flue, it must be removed before connecting the appliance to, or inserting a liner into the flue. The point of termination must not be within 600mm of an openable window, air vent or any other ventilation.

## INSTALLATION PIPES

Installation pipes should be fitted in accordance with current Gas Regulations. Pipework from the meter/tank to the cooker must be of adequate size, cooker connection size of 15mm Dia. On completion test the gas installation for soundness and purge in accordance with the regulations in force.

## AIR SUPPLY

### **Kitchen or Internal Space Air Supply**

Where the appliance is to be installed in a kitchen or internal space, it does not require the kitchen or internal space containing it to have a permanent air vent.

## ELECTRICAL

A 3 Amp 230V-50Hz fused electrical supply is required adjacent to the appliance. External wiring to the fan unit must be installed using a 3-core heat resistant silicone sheathed cable and in accordance with the current Wiring Regulations and any local regulations which apply.

The wiring should be completed as indicated:

The method of connection to the mains electricity supply must facilitate complete electrical isolation of the appliance, preferably by the use of an unswitched shuttered socket outlet in conjunction with a fused three pin plug. Alternatively, a fused double pole switch, having a contact separation of at least 3mm in both poles serving only the appliance may be used.

**NOTE:** Use the flexible metal conduit (provided) as a guide tube to route the mains supply cable through the appliance. Attach one end of tubing to the hole in the burner housing and the other end to a knock-out in either side panel, or back panel. Use appropriate fittings, also provided.



## BURNER ASSEMBLY - AIMS CONTROL

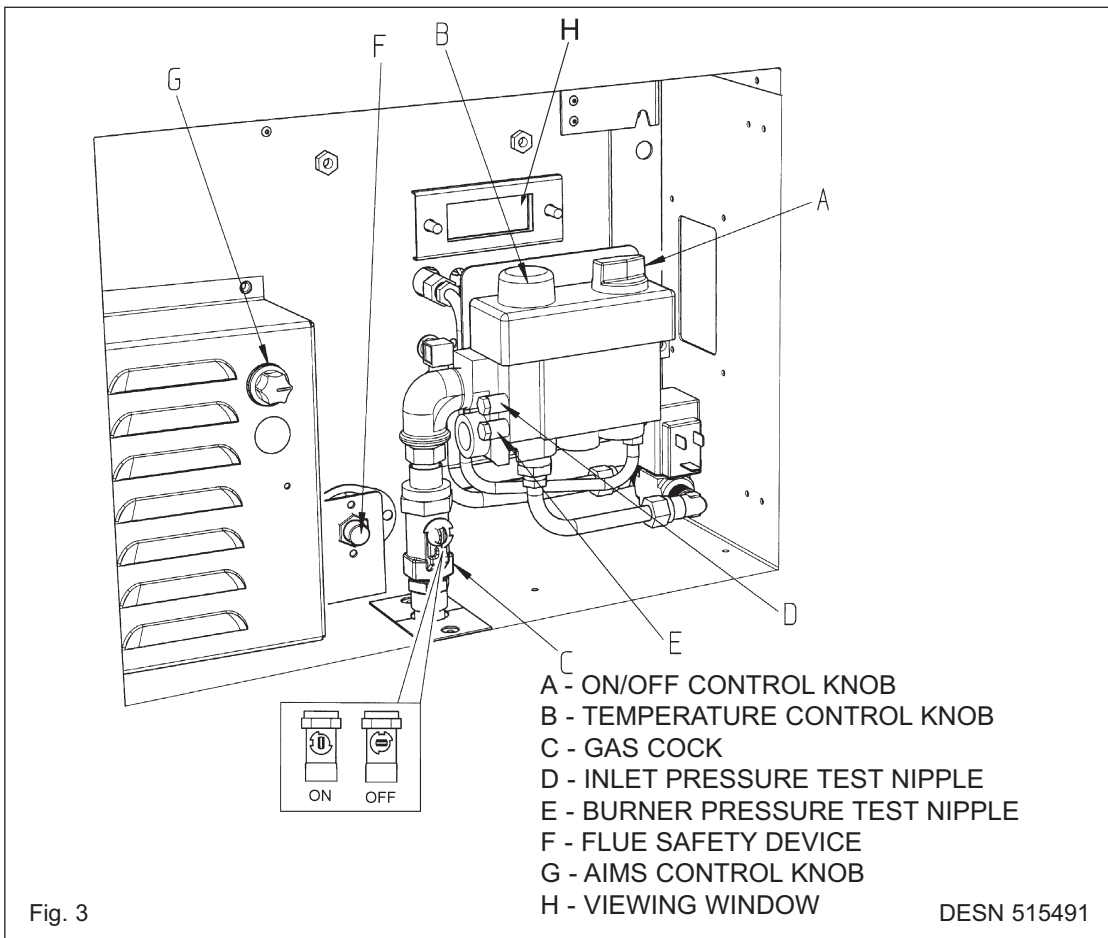

## WIRING DIAGRAM

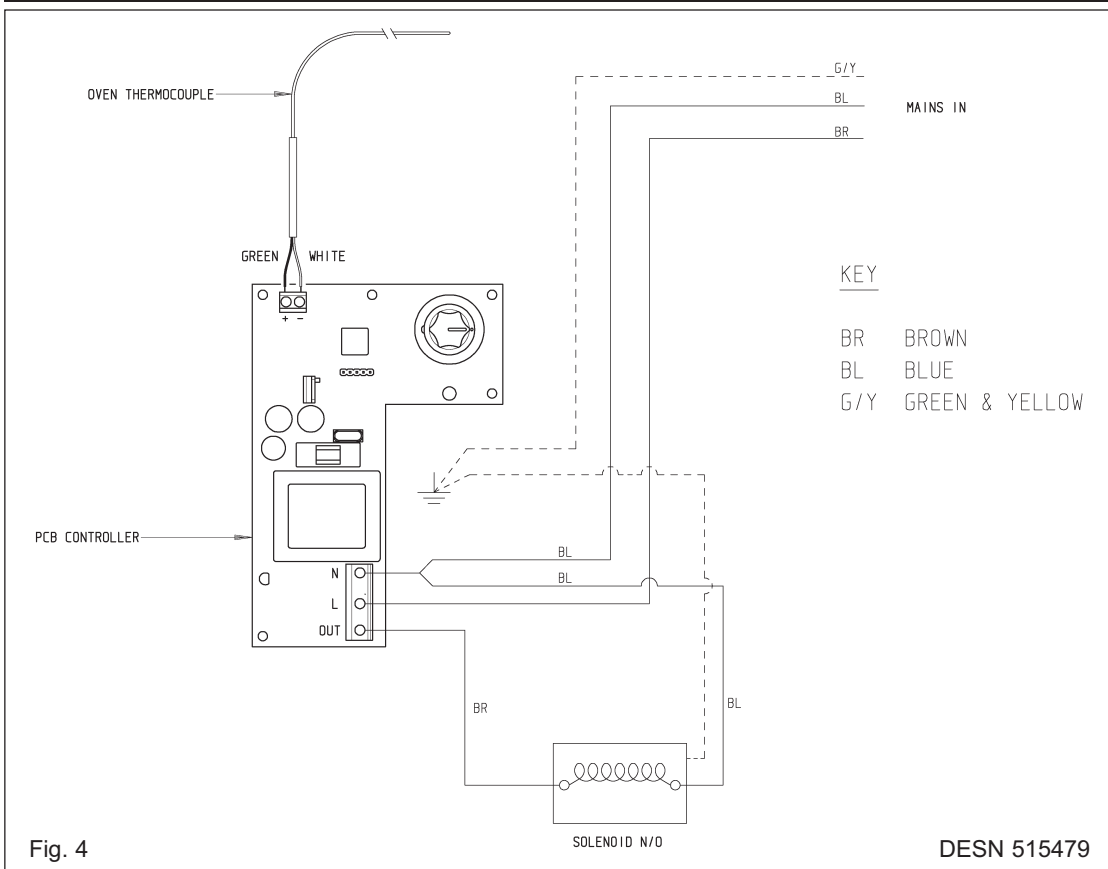

## ASSEMBLY OF BURNER - AIMS CONTROLS

SEE FIG. 3

**NOTE:** Prior to assembly remove controls mounting bracket from burner housing.

1. Fit gas cock to inlet supply pipe.
2. Fit burner assembly to burner housing.
3. Fix AIMS control mounting bracket to burner housing.
4. Fix AIMS control board to mounting bracket.
5. Attach wiring to AIMS control board (See Fig. 4) and solenoid plugs onto solenoids. Fix wires to cable clamp.
6. **WHEN FITTING AIMS CONTROL COVER:**
  - (a) Take care to route solenoid cables through notch at rear of cover.
  - (b) **The AIMS control knob must pass freely through the clearance hole in the controls cover. Avoid distorting the control spindle, as this could damage the PCB. (NOTE: It may be necessary to adjust the fit of the burner housing to front plate, to fit controls cover correctly).**

## OVEN THERMOCOUPLE

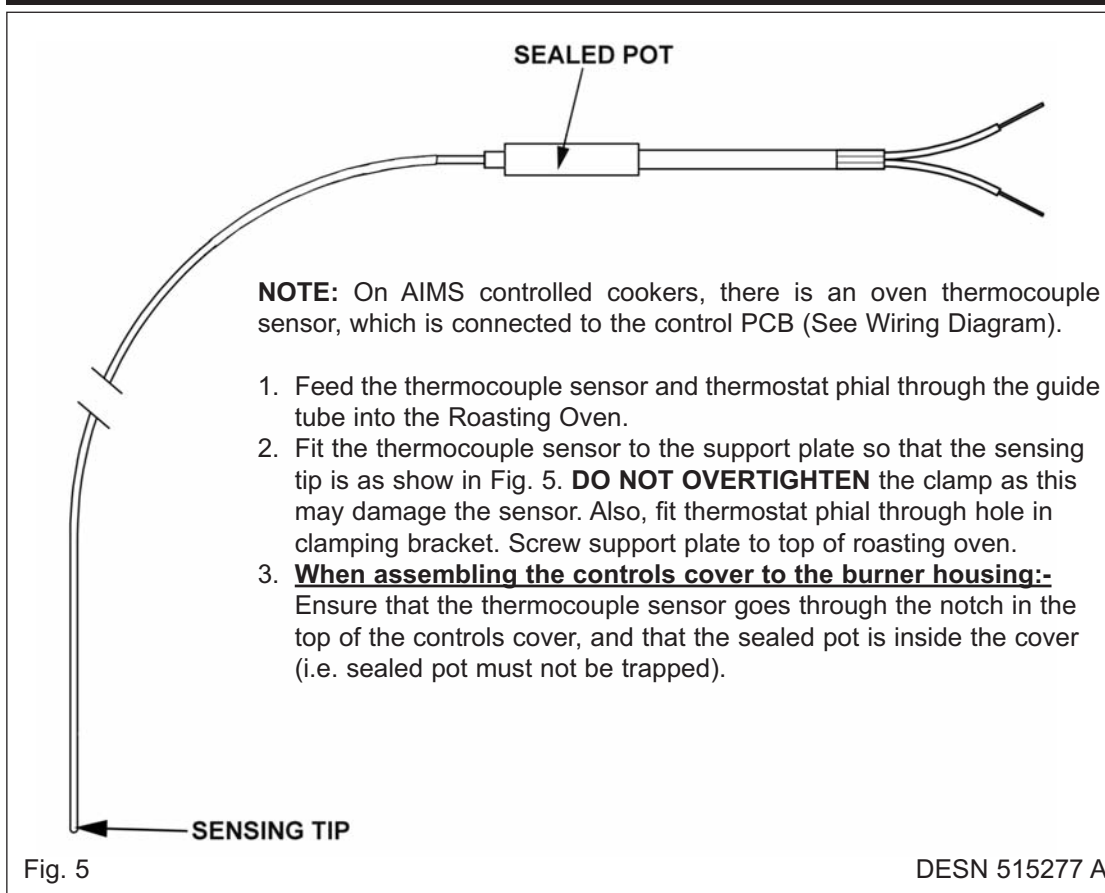

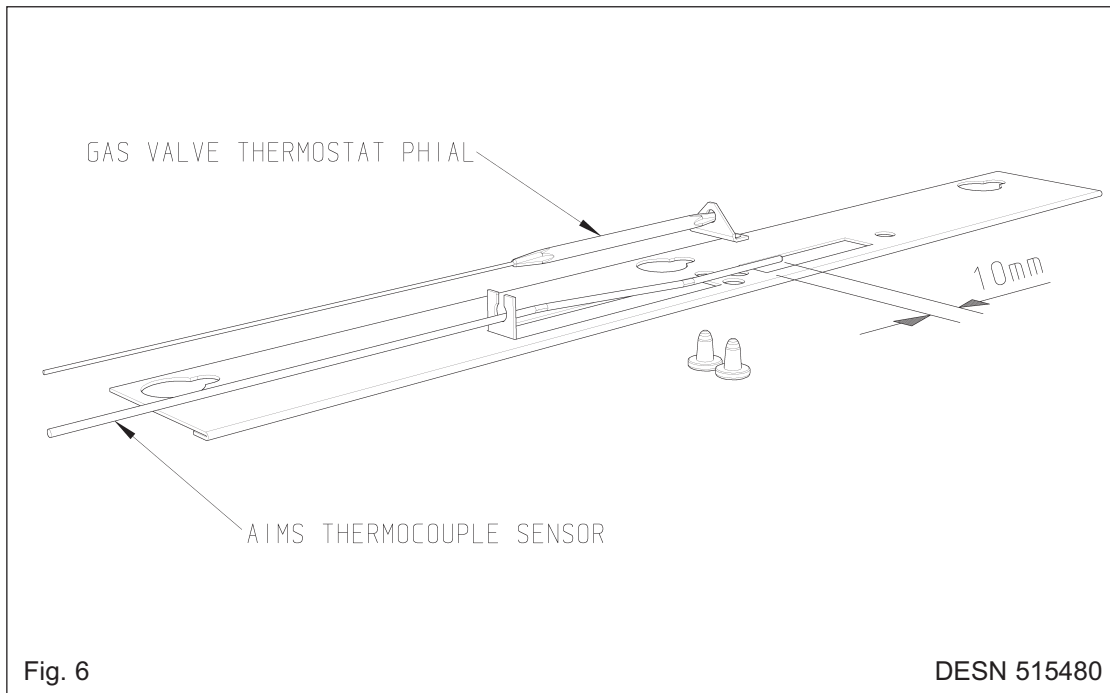

## TO TEST THE AIMS CONTROL HANDSET

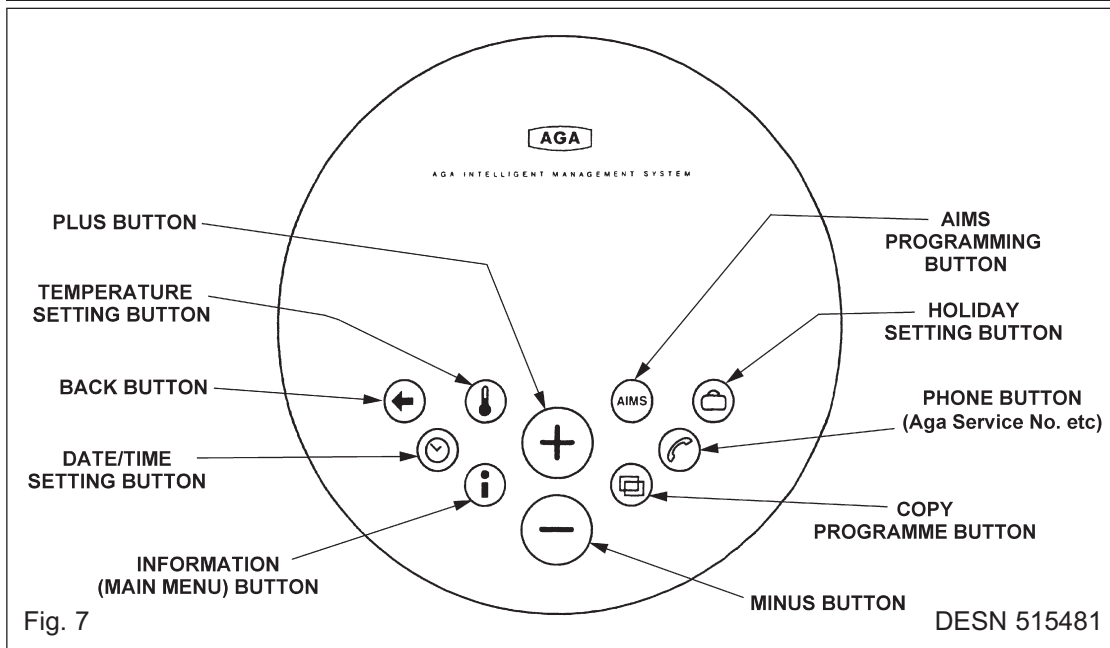

### Handset to Base Unit Signal Check/Language Selection

Complete the following procedure to check the handset is communicating with the base unit and to select language option.

1. Switch on the power supply to the cooker. Immediately, switch the control knob on the base unit back and forth between manual and AIMS setting until the blue neon flashes.
2. Immediately after neon starts to flash press and hold the + and - buttons together on the handset until the blue neon goes out completely (handset display will briefly say 'SERIAL NUMBER FOUND'), then release buttons.
3. If the neon does not extinguish completely, but continues to flash with a faint output, then repeat steps 1 and 2 above.
4. When the connection has been made, the screen will display the language options, use the + or - buttons to scroll through the options to the desired language, then press button to confirm selection.
5. If the language option needs to be changed at any time then the whole procedure must be repeated from step 1.

## COMMISSIONING

**CAUTION: BEFORE LIGHTING: ENSURE KNOB (A) IS IN THE OFF POSITION (SEE FIG. 9). ALSO ENSURE GAS SUPPLY TO COOKER IS ON, AND THE GAS SERVICE COCK (C) IS IN THE ON POSITION (SEE FIG. 3), AND THE ELECTRICAL SUPPLY TO THE AGA IS SWITCHED ON.**

### **LIGHTING PROCEDURE - SEE FIGS 8 - 16**

1. The main burner gas flow is set with the 'temperature knob' (B) (See Fig. 8). First, ensure both knobs are turned fully clockwise. Knob (A) to the OFF position and knob (B) to the minimum setting (thin end of the white band).
2. Turn ON/OFF knob (A) slightly anti-clockwise towards the IGNITION position (↺) until reaching stop, press down and hold for 5 seconds (gas flows only to the pilot burner). (See Fig. 10).
3. Continue pressing down knob (A) while turning further counter-clockwise to the PILOT position (this activates the piezo), continue to hold down for 10 seconds after pilot burner has been lit. (If the pilot does not light, steps 2 and 3 can be repeated). (See Fig. 11).
4. Upon lighting, release knob and turn further anti-clockwise to the ON position (large flame symbol) (See Fig. 12). Pilot gas flows and mains gas flows according to the temperature setting (knob B).
5. Turn the temperature knob (B) slightly anti-clockwise into the white band (LOW FIRE position). Leave in the low fire position for at least 30 minutes (See Fig. 3).

**NOTE:** 'LOW FIRE' position is attained by turning knob (B) gradually into the white band, until SMALL FLAME is observed through viewing window (F). (See Fig. 14).

6. After 30 minutes rotate control knob (B) anti-clockwise to the mid-position of the green band for normal running (See Fig. 15).

**NOTE:** After several hours the heat indicator should be within the black band on the AIMS handset 'INFORMATION' screen. It may be necessary to adjust the control knob in the green band to achieve this, allow the cooker to stabilise for at least 4 hours before attempting any further adjustment.

When the cooker is lit from cold, moisture may form on the enamel which should be wiped off to prevent staining.

**IF THE FLAME HAS EXTINGUISHED FOR WHATEVER REASON, WAIT THREE MINUTES (MINIMUM) BEFORE RE-LIGHTING.**

6. Check the inlet gas pressure is as indicated on the data plate (See Fig. 8).
  - (a) Turn knob (A) to the OFF position (Fig. 9). Unscrew the inlet pressure test nipple plug (D), and fit pressure gauge. Light the burner, turn knob (A) to the ON position (Fig. 12) and knob (B) to the mid-position of the green band (Fig. 14).
  - (b) Check inlet pressure correctly corresponds to the data plate.
  - (c) Check that the gas pressure is unaffected when other gas appliances are used.
  - (d) Turn knob (A) to OFF position. Remove the pressure gauge and replace test nipple plug (screw plug back in, but take care not to overtighten).
  - (e) Relight burner as steps 1 to 6, and check pressure test nipple for gas tightness.

## COMMISSIONING (CONTINUED)

### 7. Check burner pressure as follows:-

Repeat instruction 6 on completely cold cooker with the pressure gauge fitted to the burner test nipple (E) (See Fig. 3). Check that the burner pressure correctly corresponds with the table marked 'TECHNICAL DATA', (page 5 and 6).

**NOTE:** IF FOR ANY REASON A GAS RATE CHECK IS REQUIRED. TURN OFF ALL OTHER APPLIANCES USING GAS AND USING THE GAS METER TEST DIAL AND STOPWATCH CHECK THAT THE MAXIMUM GAS INPUT TO THE APPLIANCE IS AS INDICATED ON THE DATA PLATE.

Once the correct setting has been confirmed, the heat control will operate automatically to maintain the cooker at full temperature.

**NOTE:** REMEMBER TO NOTE THE SETTING POSITION IF TURNING OFF THE COOKER.

## INSTRUCTIONS

Hand these and the operating instructions to the User for retention and instruct in the safe operation of the appliance.

Finally advise the User that, for continued efficient and safe operation of the appliance it is important that adequate servicing is carried out at regular intervals recommended by the AGA Distributor or local Gas Region.

# BURNER CONTROLS

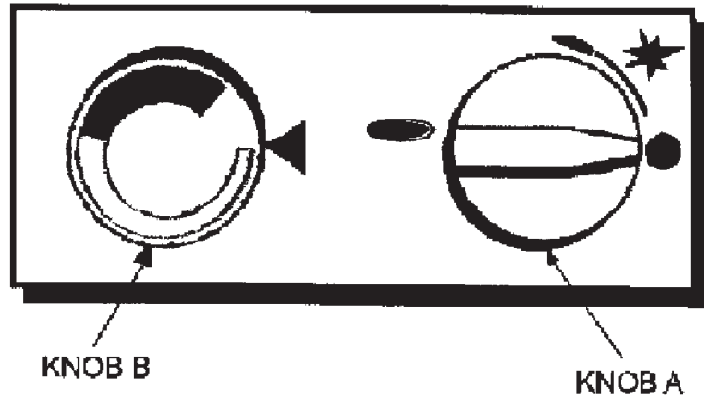
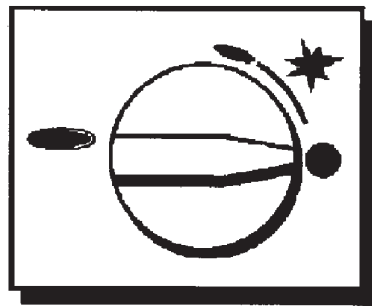

Fig. 8



OFF POSITION

Fig. 9



IGNITION POSITION

Fig. 10



PILOT POSITION

Fig. 11

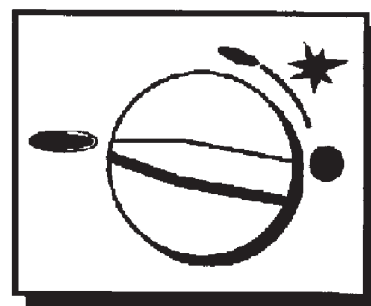

ON POSITION

Fig. 12



LOW FIRE

Fig. 13



NORMAL RUNNING

Fig. 14



**For further advice or information contact  
your local AGA Specialist**

With AGA Rangemaster's policy of continuous product improvement, the Company reserves the right to change specifications and make modifications to the appliance described and illustrated at any time



Manufactured by  
AGA Rangemaster  
Station Road  
Ketley Telford  
Shropshire TF1 5AQ  
England

[www.agaliving.com](http://www.agaliving.com)  
[www.agacookshop.co.uk](http://www.agacookshop.co.uk)