



Oil-Fired Cookers

Users Instructions for Aga Oil-Fired Cooker Models OC, OCB, (2 Oven) 2= OE, OEB, (4 Oven) =4=



Consumer Protection Act 1987

As responsible manufacturers we take care to make sure that our products are designed and constructed to meet the required safety standards when properly installed and used.

IMPORTANT NOTICE: PLEASE READ THE ACCOMPANYING WARRANTY. Any alteration that is not approved by AGA, could invalidate the approval of the appliance, the warranty and could also infringe the current issue of the statutory requirements.

Control of Substances – Health and Safety

Important:

This appliance could contain any of the materials that are indicated below. It is the Users/Installers responsibility to ensure that the necessary personal protective clothing is worn when handling, where applicable, the pertinent parts that contain any of the listed materials that could be interpreted as being injurious to health

and safety, see below for information.

Firebricks, Fuel beds, Artificial Fuels – when handling use disposable gloves.

Fire cement – when handling use disposable gloves.

Glues and sealants – exercise caution – if these are still in liquid form use face mask and disposable gloves.

Glass Yarn, Mineral Wool, Insulation Pads, Ceramic Fibre, Kerosene Oil – may be harmful if inhaled, may be irritating to skin, eyes, nose and throat. When handling avoid inhaling and contact with skin or eyes. Use disposable gloves, face masks and eye protection. After handling wash hands and other exposed parts. When disposing of the product reduce dust with water spray, ensure that parts are securely wrapped.

YOUR AGA COOKER

Your AGA is an oil-fired, heat-storage cooker. The burner operates at either high or low fire and is controlled by the cooker thermostat which is linked to the oil control box. In the event of a power failure the burner will automatically continue to operate on low fire. Should there be a prolonged power cut the burner can be operated under manual control. However, for the most effective operation of the cooker the following points should be carefully observed:

1. Close the insulating lids whenever the hotplates are not in use.
2. Clean the hotplates regularly with the wire brush.
3. Utensils with ground flat bases must be used to make perfect contact with the hotplates.

4. The hot water system must be thoroughly insulated (Model OCB & OEB).
5. Have the cooker serviced at regular intervals a competent service engineer such as OFTEC approved.
6. Take care, when closing the oven doors, to lift them onto the catch.

Your AGA is also supplied with the following accessories:

1. Large roasting tin with grill rack.
1. Half-size roasting tin with grill rack.
2. Oven Grid Shelves.
1. Plain Shelf.
1. Wire Brush.
1. Toaster.
1. AGA Book.

A full description of cooking with your AGA is given in the AGA Book.

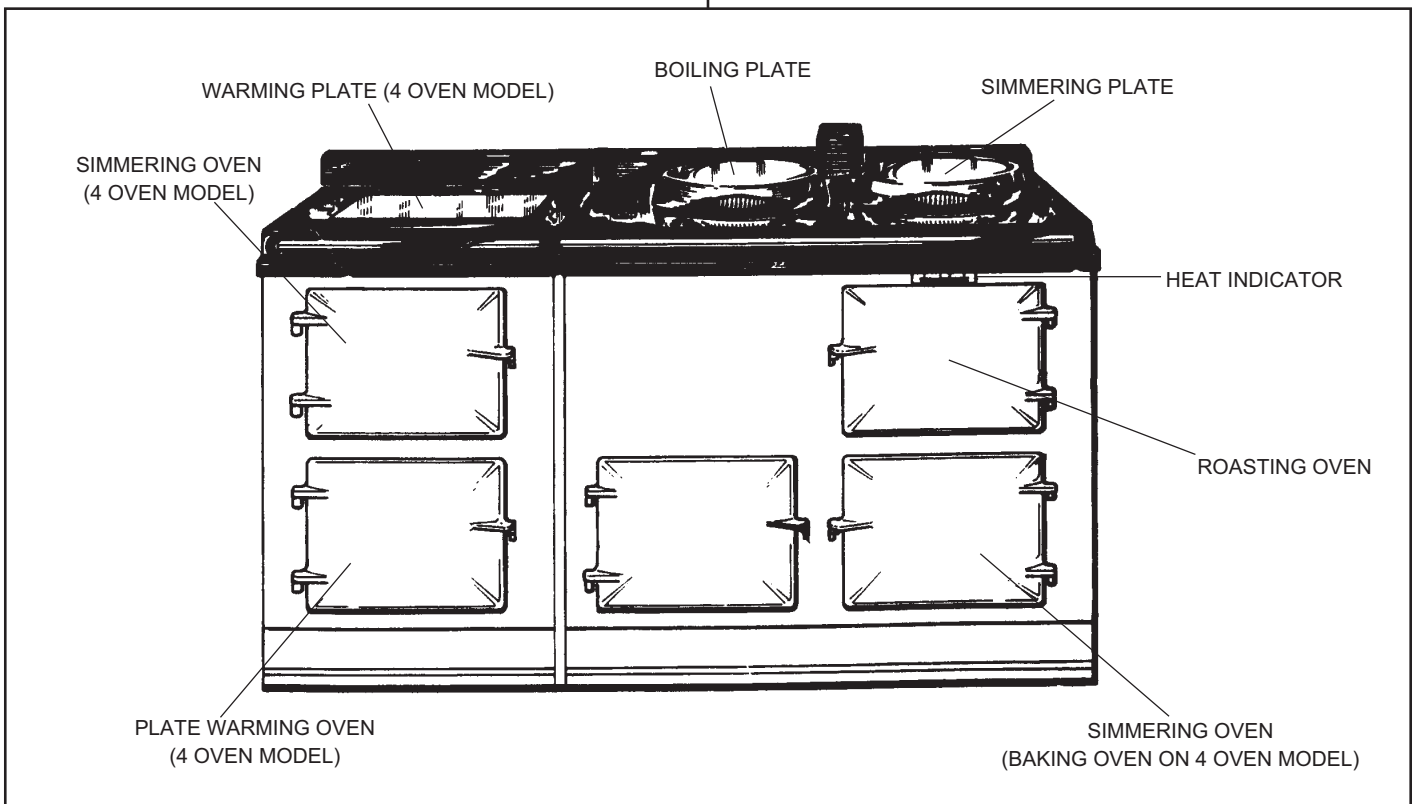

THE HEAT INDICATOR

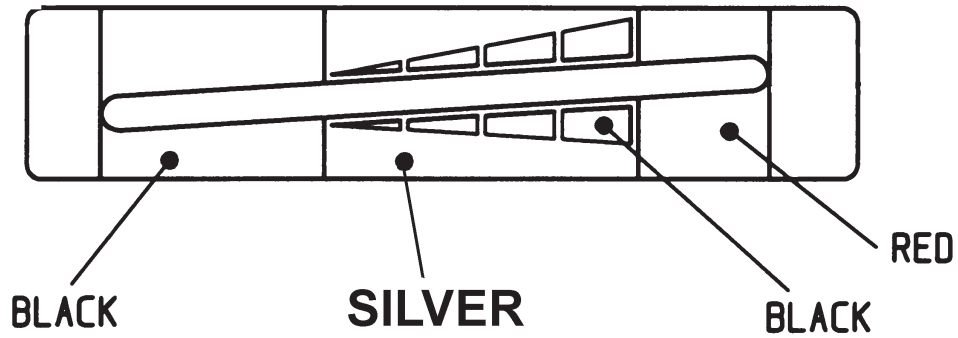

Fig. 2

DESN 515920

The heat indicator above the Roasting oven door is a guide to the stored heat within the AGA, and does not directly relate to the Roasting oven centre oven temperature.

It has 3 sections black, silver and red.

To obtain your preferred working temperature the control knob can be adjusted slightly. Once set it is not recommended to adjust on a regular basis. An AGA is designed to work at an optimum setting.

The optimum performance is usually achieved when the indicator is showing a mid-way position in the silver area.

Since the purpose of the heat indicator is to show that the AGA contains the full amount of stored heat it is best to refer to it first thing in the morning or after a period of several hours during which no cooking has been done.

NOTE: IT DOES NOT INDICATE THE OVEN TEMPERATURE.

AUTOMATIC CONTROL

The setting of the thermostat control knob (alongside the burner inner door) at No. 4 should normally ensure that the cooker runs at the correct temperature, with the indicator on or about the centre of the silver section of the heat indicator. Any discrepancy can be resolved by marginally advancing or retarding the knob to compensate - the higher the number, the higher the temperature setting.

Once the correct setting has been confirmed, the control will operate automatically to maintain the cooker at full temperature and need not be altered.

MANUAL CONTROL

Without an electric supply to the control box, the burner will operate continuously on 'Low Fire'. In the event of a power failure, the burner can be switched to 'High Fire' by simply moving the manual high fire lever on the top of the control box Fig. 4 from **RIGHT** to **LEFT** and engaging it back in the slot in the cover.

The lever should be returned to its normal position when cooking is finished or when the power is restored.

THE CORRECT OIL

The natural draught vapourising burner is designed to burn commercial kerosene to the Current Issue of BS2869: Class C2 suitable for vapourising burners.

OTHER GRADES OF OIL MUST NOT BE USED IN ANY CIRCUMSTANCES.

TO EXTINGUISH THE BURNER

Turn control knob fully clockwise to 'O'. This will cut off the oil supply to the burner which will gradually die out.

NEVER ATTEMPT TO RE-LIGHT A HOT BURNER.

If the cooker is being left out of use for more than a few hours or if the fuel supply has run out, turn off the valves on the oil feed line from the storage tank.

TO LIGHT THE BURNER

1. Open all valves on the oil feed pipe from the storage tank to the burner oil control box. Turn control knob fully anti-clockwise.
2. Switch on electric supply to the oil control box.
3. Lift up the reset lever on the oil control box Fig. 4. until it clicks.
4. Check that manual lever on oil control box is set at automatic (positioned to the right).
5. Open burner outer door and lift off inner door. Allow about fifteen minutes for oil to enter burner. Then open the lighting flap Fig. 3 on burner outer shell position. Taking care not to lift or disturb the burner shell position. Insert a match which will light the wick.

Close the flap and replace the inner door and switch off electric supply to the oil control box.

On lighting the flames will gradually come up and burn yellow, but will soon die down. It will take about 20-30 minutes for the burner to become hot before oil will vaporize properly. Observe through the sight glass on the inner door the condition of the flame when it has settled down, which should be burning blue with the shells glowing red. Then switch on electric supply to the oil control box and the burner will operate under control of the cooker thermostat.

On lighting condensation will form in the flue ways and may run onto the top-plate from the flue chamber, this should be wiped off to prevent any possibility of damage to the vitreous enamel.

FIRE VALVE-RESETTING

NEVER ATTEMPT TO RE-LIGHT A HOT BURNER.

Down draught can sometimes occur in windy conditions causing the fire valve to close, and thus isolating the oil supply as a safety precaution.

The fire valve, located at the side of the appliance (See Fig. 3) can be reset once the unit has sensed the correct functional temperature.

TO RESET: press button (See Fig. 6) and if the button stays in, the appliance is fully functional again. If the button springs out, more cooling time must be given before trying again.

In the event of the fire valve frequently cutting-out, consult your Aga Distributor.

NEVER ATTEMPT TO RE-LIGHT A HOT BURNER.

SERVICING

For safety and reliability, it is important that servicing is carried out at regular intervals by a competent service engineer such as OFTEC approved **ONCE EVERY SIX MONTHS**. The cooker should be turned **OFF** by the User the night preceding the day of servicing so that the appliance will have cooled down by the following morning.

A HOT APPLIANCE CANNOT BE SERVICED.

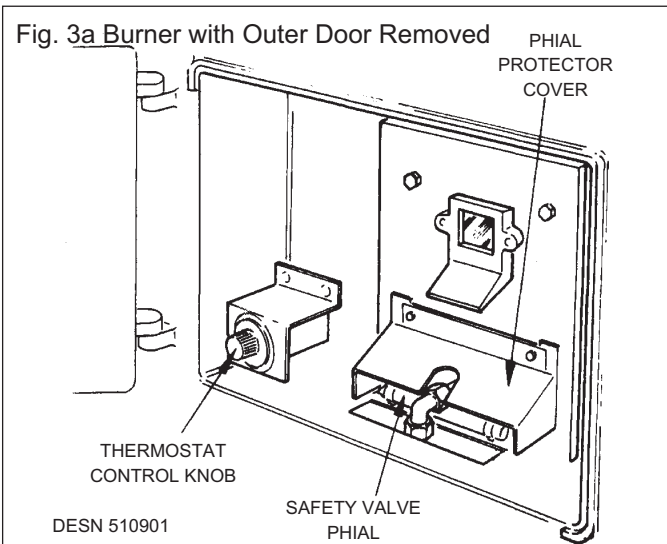

Fig. 3b Burner with Inner Door Removed

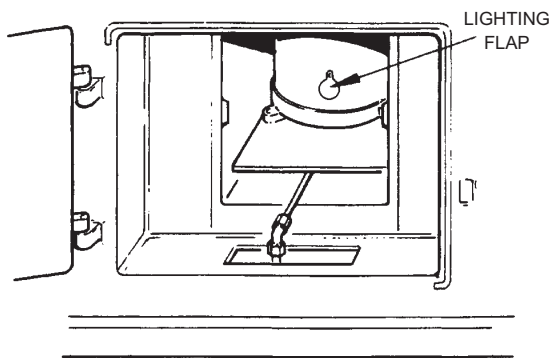

Fig.3 Oil Burner

DESN 510902

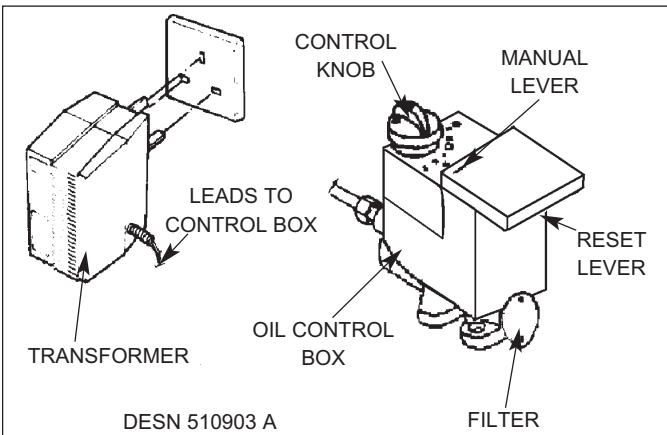

Fig. 4 Oil Control Box and Transformer

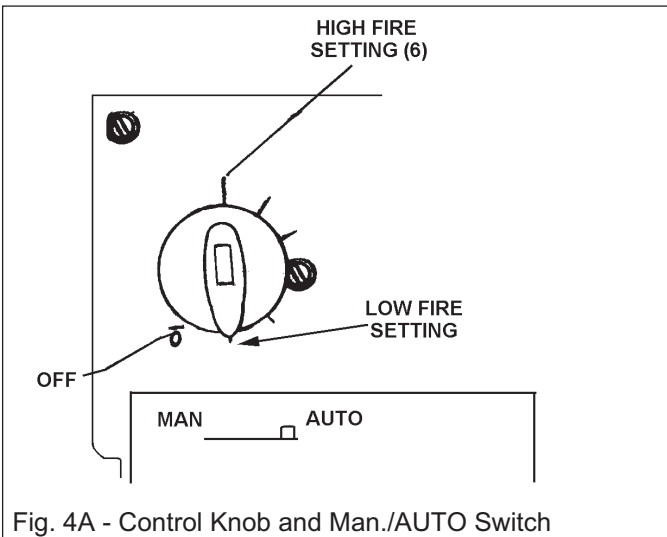

Fig. 4A - Control Knob and Man./AUTO Switch

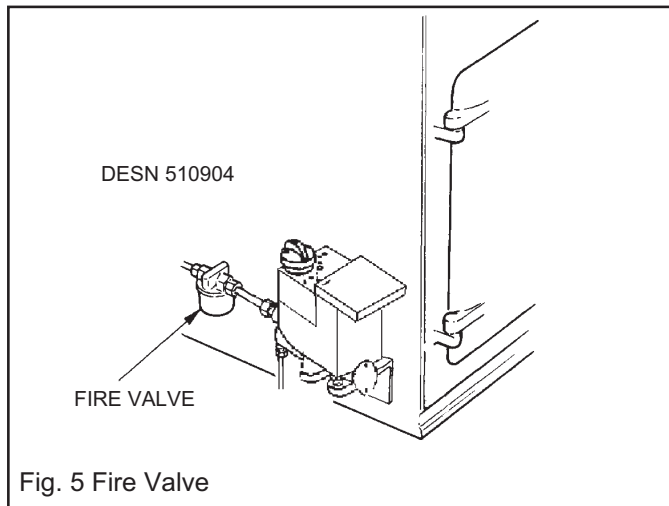

Fig. 5 Fire Valve

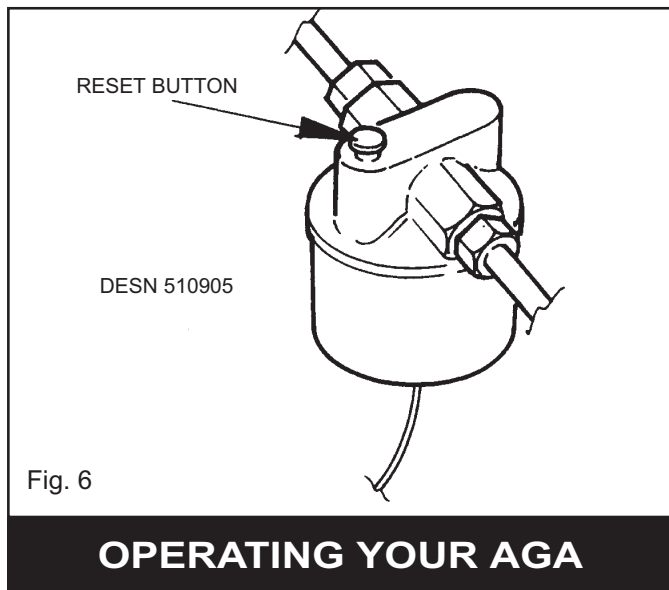

Fig. 6

OPERATING YOUR AGA

The following points are intended to help you during the period of change-over from your previous cooker to the AGA way of life.

You will also find that the AGA Book provides a very useful introduction to the cooker.

After Your AGA has been Erected

When it first lit, your AGA will emit an odour for a short while.

Do not worry, this is simply due to protective oil burning off the hotplates. If you can wipe the inside of the hotplate lids whilst the AGA is heating up it will avoid a film of this oil being deposited on the inside of the lids.

Beginning to Cook on your AGA

The first "Golden Rule" of the AGA is to cook as much as possible in the ovens - without changing your menus. This not only conserves heat but also reduces cooking smells and condensation into the kitchen.

The Roasting Oven can also be used for grilling (at the top) and shallow frying (on the bottom).

Do keep the insulated lids down when the hotplates are not in use so that the heat stored in the cooker is conserved.

For the optimum cooking performance, use the AGA utensils and the AGA cast iron cookware. They all have thick ground bases which give the best contact with the hotplates.

The AGA pans can be stacked in the Simmering Oven. This is especially useful for steaming vegetables and simmering sauces.

Store the Plain Shelf out of the AGA. Use it, cold in the Roasting Oven on a 2 oven AGA to deflect the heat from the top of the oven thus creating a more moderate oven temperature. It can also be used as baking sheet.

The AGA Cake Baker can be used in the 2 oven AGA for cakes needing over 45 minutes cooking.

A guide to AGA cooking is given overleaf. Ask your Distributor for an invitation to an AGA demonstration.

FITTING OF OVEN SHELVES

If this is the first time you have used this type of oven shelf, go through the procedure of changing the oven shelf with the aid of Figs.7 to 10.

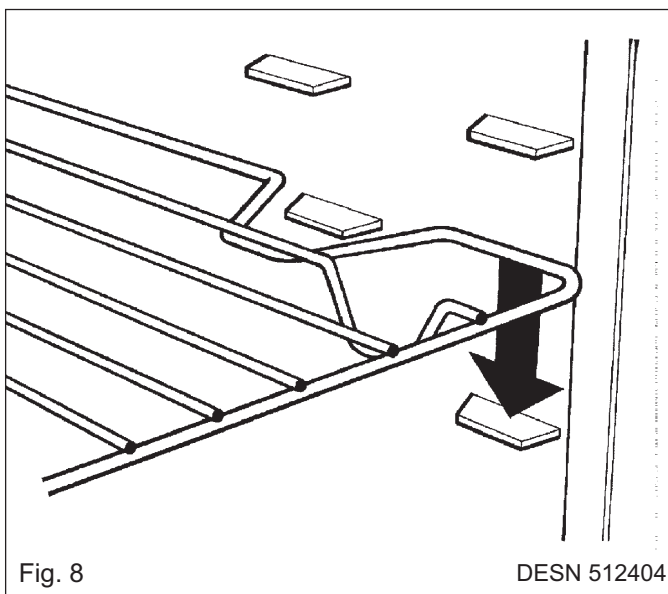
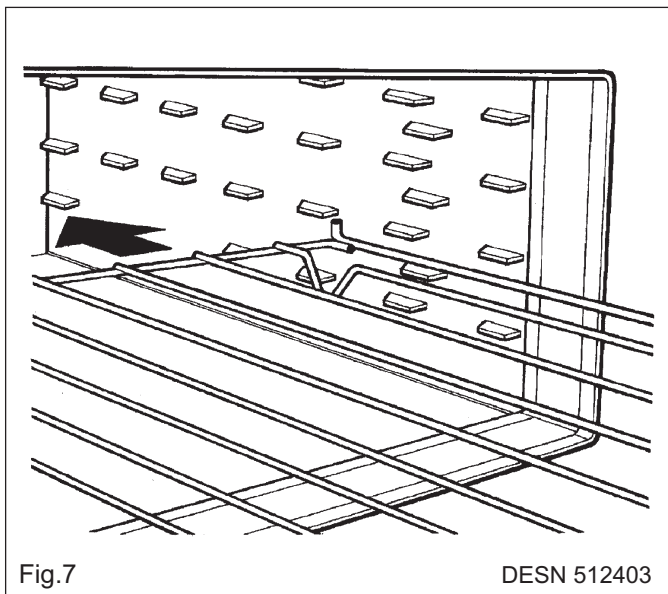

REMOVAL OF OVEN SHELVES

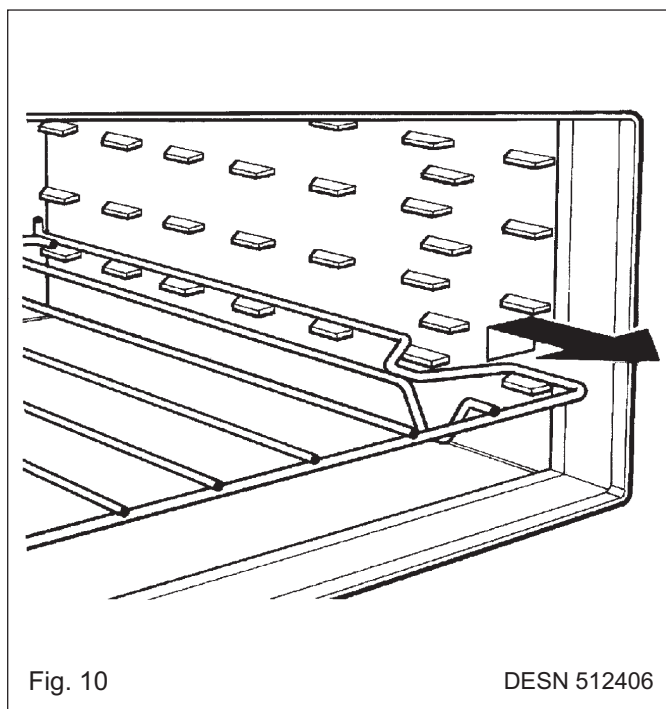
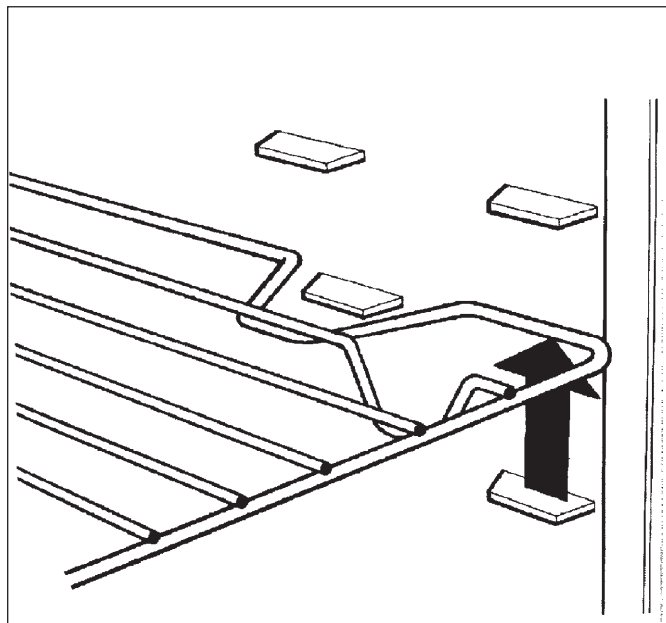

CLEANING AND CARING FOR YOUR AGA

REMEMBER: BE CAREFUL OF THE HOT APPLIANCE.

DO NOT USE ABRASIVE PADS OR OVEN CLEANER

Top Plate and Front-plate

The easiest way to clean the AGA top plate and front plate is to mop up spills as they happen. Baked-on food is more difficult to clean but can usually be removed with proprietary vitreous enamel cleaners or mild cream cleaners using a cloth, or if necessary, a nylon scouring pad. If milk or fruit juice or anything containing acid, is spilt on the AGA, wipe it up immediately.

Also clean off any condensation streaks on the front-plate around the oven doors or the vitreous enamel maybe permanently discoloured.

All that is usually needed to keep the vitreous enamelled surfaces of your AGA bright and clean is a daily rub-over with a damp soapy cloth followed immediately with a clean, dry cloth to avoid streaks.

Remember the top-plate and the chrome lids will scratch if pans or utensils are dragged across them.

Insulating Lids and Oven Doors

The linings of the insulating lids and oven doors may be cleaned with a cream cleanser or soap impregnated pad.

Open the lids and lift off the oven doors to allow them to cool a little before cleaning. Do not, however, immerse the doors in water as they are packed with insulating material which will be damaged by excessive moisture.

Refer also to the Cleaning Section in the AGA Book.

Ovens and Hotplates

The cast-iron ovens help to keep themselves clean; they merely need to be brushed out occasionally with a long-handled stiff brush. The Simmering and Plate Warming Ovens on the 4 oven AGA may be cleaned with a damp soapy cloth.

The wire brush is provided for cleaning the hotplates and any burnt-on spills in the cast iron ovens.

DO NOT USE OVEN CLEANERS.

Roasting Tins

The roasting tins should be cleaned in hot soapy water, soak if necessary, a nylon scouring pad can be used.

Important: AGA recommend Vitreous Enamel Association approved cleaners for cleaning enamelled surfaces of this product.

But it is unsuitable for use on: chrome and stainless steel components including the insulating, hand-rails and their brackets.

The insulating covers should be cleaned regularly with a **NON-ABRASIVE** mild detergent, applied with a soft (coarse free) cloth and lightly polished up afterwards with a soft (coarse free) duster or tissue, to bring it back to its original lustre.

GUIDE TO AGA COOKING

As the AGA Cooker is heated differently from an ordinary cooker, exact conversions are not possible. Look in the AGA Book for a similar recipe. Below is a quick guide to oven usage.

OVEN TEMPERATURE	2=TWO OVEN AGA	=4=FOUR OVEN AGA
HIGH	ROASTING OVEN	ROASTING OVEN
GRILLING SCONES PASTRIES BREAD YORKSHIRE PUDDING ROASTS SHALLOW FRYING	Top - Grilling; 2nd runner - Scones, Small Pastries; 3rd runner - Bread Rolls, Yorkshire Pudding; 4th runner - Roasts, Poultry, Small Cakes in cases in the large meat tin. Grid shelf on oven floor - Loaves. Oven floor - Shallow frying. Quiche.	Top - Grilling; 2nd runner - Scones, Small Pastries; 3rd runner - Bread Rolls, Yorkshire Pudding; 4th Runner - Roasts, Poultry. Grid shelf on oven floor - Loaves Oven floor - Shallow frying, Quiche.
MODERATE	ROASTING/SIMMERING OVEN	BAKING OVEN
CAKES BISCUITS FISH SOUFFLÉS SHORTBREAD CHEESECAKES	Place grid shelf on floor of Roasting Oven. Protect food with the cold plain shelf slid on second or third runners. For cakes that require over 45 mins use the Cake Baker. Alternatively with fish, cheesecake, start off in Roasting Oven, finish in Simmering Oven.	Towards top - Whisked Sponges, Some Biscuits, Small Cakes Middle - Fish, Soufflés. Grid shelf on oven floor - Victoria Sandwiches, Shortbread and Cheesecake
LOW	SIMMERING OVEN	SIMMERING OVEN
CASSEROLES STOCK MILK PUDDINGS MERINGUES RICH FRUIT CAKE	For Casseroles, Stock, Milk Puddings, bring to heat elsewhere on the Aga then transfer to Simmering Oven. (One exception is Meringues). Rich Fruit Cakes can be cooked for a long time here	For Casseroles, Stock, Milk Puddings, bring to heat elsewhere on the Aga then transfer to Simmering Oven. (One exception is Meringues). Rich Fruit Cakes can be cooked for a long time here.

**For further advice or information contact
your local AGA Specialist**

With AGA Rangemaster's policy of continuous product improvement, the Company reserves the right to change specifications and make modifications to the appliance described and illustrated at any time.



Manufactured by
AGA Rangemaster
Station Road
Ketley Telford
Shropshire TF1 5AQ
England

www.agaliving.com
www.agacookshop.co.uk