



# FUSION PELLET STOVE



*Operating & Installation Manual*

---

---

## TABLE OF CONTENTS

NO.	PAGE
1. Standards . . . . .	2
2. Recommendations . . . . .	2
3. General Notice . . . . .	2
4. Assembly & Installation Instructions . . . . .	3
5. Hearth Dimensions . . . . .	3
6. Stove Dimensions . . . . .	3
7. Safety Warnings . . . . .	4
8. Flue - Vertical External or Internal Chimney . . . . .	4
9. Combustion Air . . . . .	5
10. Safety & Correct use of the Appliance . . . . .	5
11. In Case Of Chimney Fire . . . . .	6
12. Fuel . . . . .	6
13. Pellet Loading . . . . .	6
14. Notes on Operation . . . . .	6
15. Operating Sequence & Switching Off . . . . .	7
16. Electronic Control Panel . . . . .	9
17. Remote Control Functions . . . . .	9
18. Circuit Board Wiring Diagram . . . . .	10
19. Managing Alarms . . . . .	11
20. Switching Off . . . . .	11
21. Safety Devices . . . . .	12
22. Cleaning Of The Stove . . . . .	12
23. Ashpan & Burn Pot . . . . .	12
24. Cleaning The Ashpan . . . . .	12
25. Glass . . . . .	13
26. Periodic Cleaning Of Stove & Heat Exchanger . . . . .	13
27. Cleaning The Flue . . . . .	13
28. End of Season . . . . .	13
29. Problems / Causes / Solutions . . . . .	14
30. Technical Information . . . . .	16

---

## STANDARDS

**N.B.:** The information in this manual is given only as a general guide, and local, national or EC regulations must also be complied with.

## RECOMMENDATIONS:

Before using this appliance, please read all parts of this instruction manual carefully, as the information it contains, is essential in order to use the appliance correctly.

Read this manual prior to installation, maintenance & operation of this appliance.

The manufacturer will not be responsible for any modifications made to this appliance by or on behalf of the user. The manufacturer will not be responsible for any eventual damage or loss as a result of unauthorised modifications. In the event that parts need to be replaced, only use parts recommended by Aga.

The user is responsible for all work involved in the initial installation of the appliance and for keeping it working efficiently thereafter.

Incorrect installation may result in damage to property, or injuries to persons or animals. The manufacturer will not be liable for any damage resulting from incorrect installation, or failure to follow the instructions that accompany this appliance.

## GENERAL NOTICE

**Important:** The appliance MUST be earthed.

Before installing the appliance, the power supply system must be checked to ensure it has an effective earth circuit.

**Important:** the power supply cable must be of sufficient cross-section for the power requirement of the appliance.

The supply voltage required for the stove is 220-240 V at 50 Hz. Voltage variations greater than 10% of the rated value may cause irregular operation, or damage to the electrical system. The appliance must be positioned so that the domestic power supply plug remains accessible.

If the power supply cable becomes damaged, switch off the power and have it repaired by an authorised Aga service agent.

Do not use a flexible liner to connect this appliance to a flue system.

## ASSEMBLY AND INSTALLATION INSTRUCTIONS

**N.B.** To install the stove, use only authorised and trained personnel, or contact the dealer.

1. Check that the floor can support the total weight of the stove (140kgs).
2. Refer to the figure that shows the dimensions of the flue pipe, and allowing for the thickness of the floor-protection base (if applicable), make a hole in the chimney to accommodate the smoke outlet pipe (diameter 80 mm).
3. Connect the stove to the chimney with a certified steel pipe suitable for this use and seal it. This appliance must not be connected to a shared flue.
4. Leave adequate clearance around the stove for cleaning and servicing. If the appliance is to be installed in an alcove a minimum of 400mm clearance is required all round to allow access for cleaning and servicing. This appliance has adjustable legs

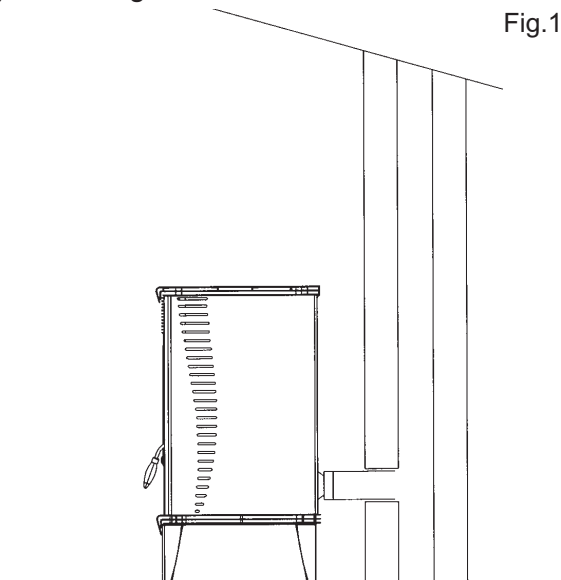

Fig.1

## HEARTH DIMENSIONS

The hearth should extend 150mm to the rear of the stove and 150mm to both sides and 30cm to the front.

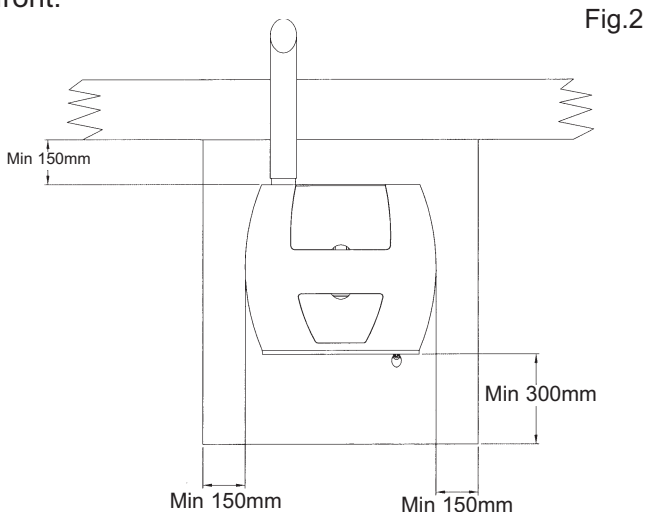

Fig.2

## STOVE DIMENSIONS (MM)

Fig.3

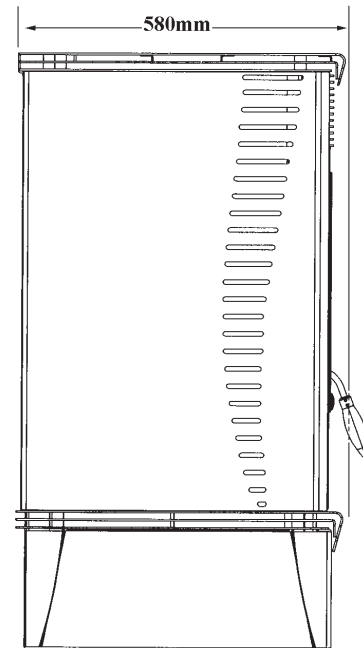

Fig.4

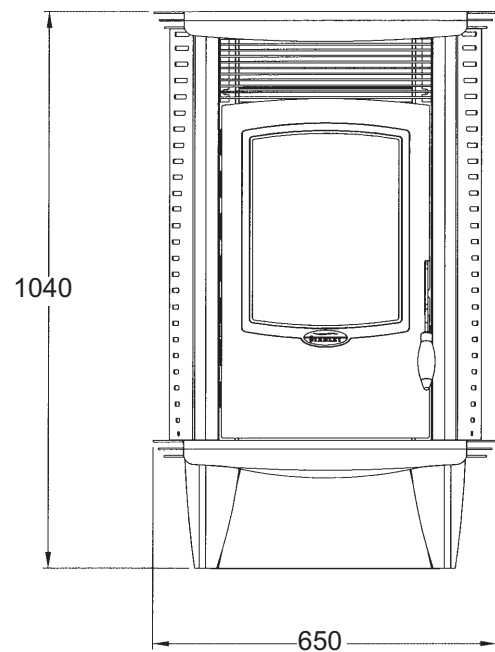
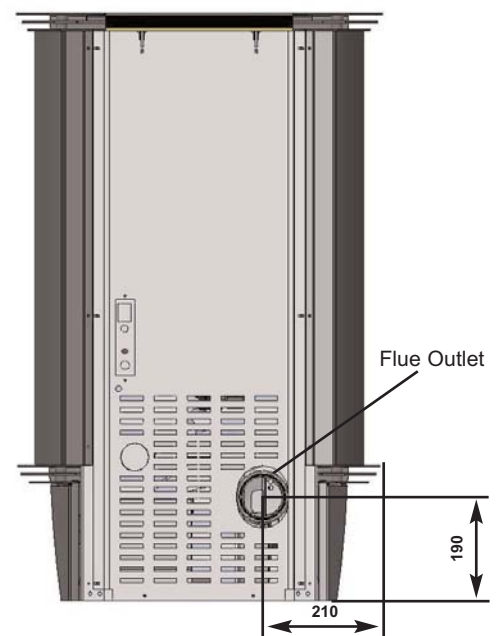

Fig.5



## SAFETY WARNINGS

This appliance is not suitable for connection to a shared flue.

The stove must be placed on a non combustible hearth. If it is to be supported on a combustible floor surface, it must be supported on a floor-protection plate of at least the size shown in 3.1. It must be at least 8mm thick.

The appliance must be connected to a chimney suitable for solid fuels with a minimum diameter of 80 mm, and with a minimum height of 2.00 m from the appliance flue outlet.

For insulating and sealing the pipes, use only heat-resistant materials (250° C).

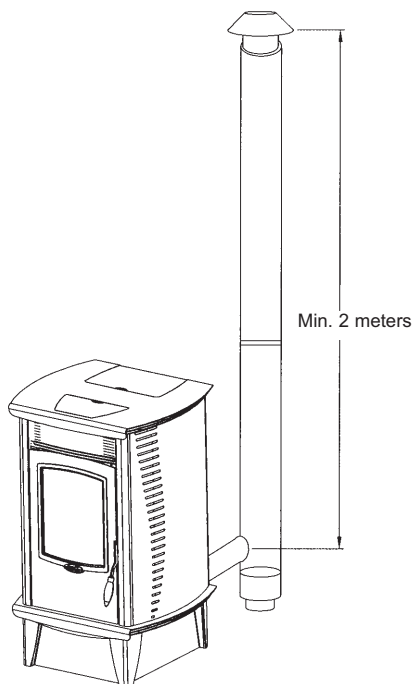

Fig.6

## FLUE - VERTICAL EXTERNAL OR INTERNAL CHIMNEY

The flue arrangement shown is the best solution for evacuating smoke, even when the ventilator is off (no power supply, or lock out flame). Any installation must comply with current building regulations.

The minimum 2.00 metre level difference between the roof outlet and the T fitting inside or outside the building, ensures a minimum vacuum inside the stove, thus preventing smoke issue into the room.

External flues must be insulated: for example by using double-wall flue pipes.

The figure shows the recommended arrangement for flue outlets above roof level. In all cases, there must be a T fitting with inspection plug. The flue duct must be suitably fastened and fitted with a chimney pot for rain protection.

The through-holes in walls or floors must always have an insulated tube or ventilation passage, so that it is always possible to disassemble the chimney components for cleaning and inspection, and to prevent contact between these components and wall masonry or inflammable surfaces.

Fig.7

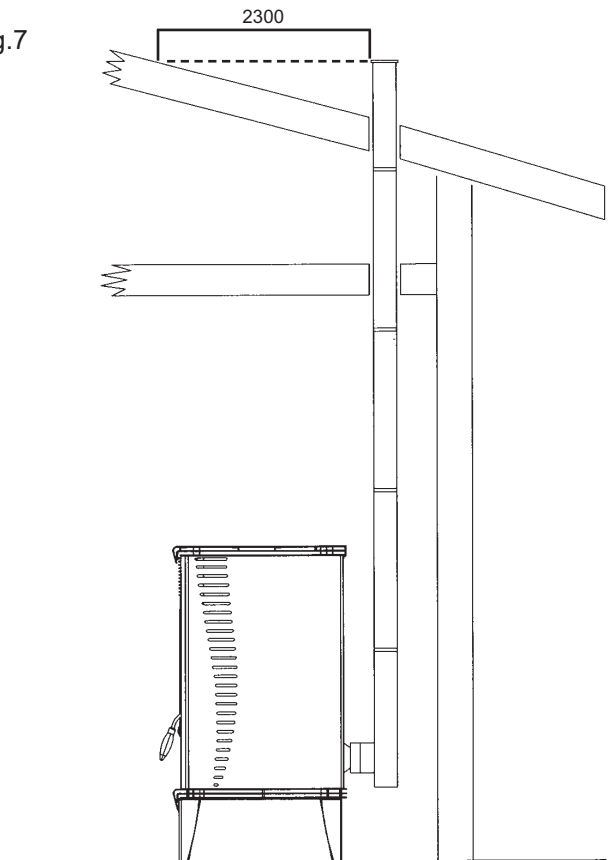
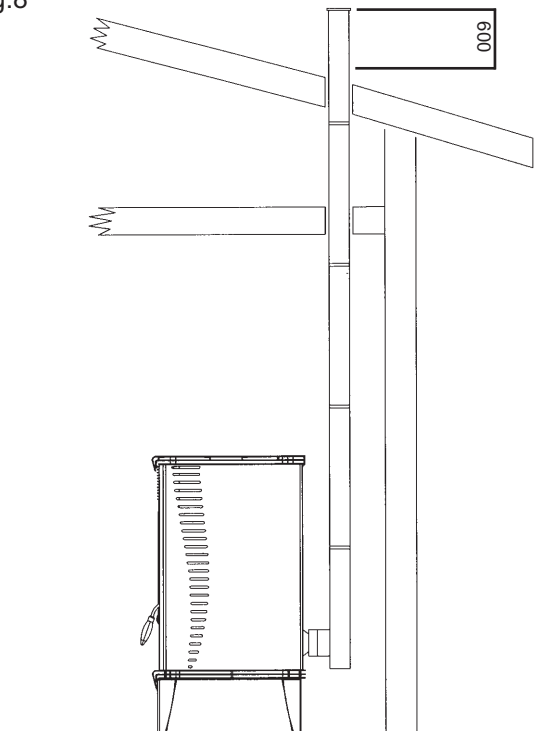

Fig.8



It is useful to have planned inspections of the pipe bends for periodic maintenance of the flue duct. The smoke outlet pipe must be protected against rainwater ingress.

Where it is necessary to have a horizontal length of pipe, there must be a minimum positive gradient of 3% along its length.

Do not run flue pipe in a horizontal plain or in a reverse gradient.

Do not install the smoke outlet at pavement level, on public streets, car-parks or anywhere that might cause annoyance to people and/or animals.

The flue must be installed with the outlet above roof level complying with current building regulations. A maximum flue length of 8 metres is allowed. For each 90° bend or T fitting, reduce the length by one metre. A minimum flue draught of 10 Pascals is required.

**IMPORTANT:** All sections of the flue pipe must be accessible for inspection, and allow for internal cleaning, removal or substitution.

Do not place a net or grill over the flue outlet. When they become dirty they will obstruct the outlet and cause poor combustion, and the stove may be blocked with soot.

## COMBUSTION AIR

The process of combustion requires oxygen, and therefore air. When in operation, the stove draws air from the room in which it is installed; poor combustion may therefore result if the room is insufficiently ventilated.

To resolve this problem, a suitable vent hole must be provided to allow a permanent supply of fresh air from the outside. The cross-section of the vent must be 6 cm<sup>2</sup> for each kW of energy consumed at maximum input therefore the ventilation hole must have a cross-sectional area of 83 cm<sup>2</sup> if a flue draught stabiliser is fitted.

If no flue draught stabiliser is fitted the ventilation requirement is 44cm<sup>2</sup>.

If the stove is located in a room containing another appliance cooker hood or extractor fan, it is essential to provide ventilation equivalent to the sum of the air requirement for all appliances.

The vent must not be placed directly beside the appliance in order to avoid drawing in air that is too cold: at certain times of the year when the appliance is very cold, the stove may be locked out when you first attempt to light it. If this occurs, the situation should be considered absolutely normal, and you can unlock the stove using the switch #4 located on the control panel. Then switch on again.

## SAFETY AND CORRECT USE OF THE APPLIANCE

Before switching on for the first time, read the following safety instructions.

1. Some parts of the stove become hot (door, glass, flue, etc.), and contact with these parts may cause burns.
2. Do not place combustible or inflammable materials beside the stove, and never at less than 1 metre.
3. Do not store bags of pellets close to the stove.
4. Your stove burns pellets only - it is not an incinerator. It is forbidden to burn other materials or household waste as fuel.
5. When loading pellets into the tank, avoid pouring sawdust along with them. Failure to follow this instruction may make the appliance unsafe, and void all warranties.
6. Keep children away from this the stove. Do not open the door when the stove is lit.
7. Do not switch off the electric power supply while the stove is on. This will cause the smoke extractor fan to stop, and the burning fuel will cause smoke to issue into the room if there is no natural upward draught in the chimney.
8. When the stove is lit for the first time, the varnish may release fumes, and these may emit an unpleasant odour. The room must therefore be ventilated to evacuate these fumes. The varnish will be fully hardened after several heating cycles (2-3). On first lighting the stove may lockout as there is no pellet in the feed. The display will show ALARM NO FIRE. The stove has to be switched off and on again to reset.
9. Periodically ensure that the gaskets between stove and flue pipe are gas tight.
10. In case of fire, switch off the stove, move any flammable materials away, and call the fire services.

## IN CASE OF CHIMNEY FIRE

Switch off appliance and close all openings into the stove, watch for ignition of adjacent combustibles from hot embers or sparks from chimney.

## FUEL

### WHAT ARE PELLETS?

PELLETS consist of sawdust or real wood scraps ground and pressed into small cylinders about 6 mm in diameter and 20-30 mm in length.

As fuel, pellets are completely environmentally friendly, as they are made entirely of natural wood, without glue or other chemical compounds. Pellets have a high calorific value (4.7 to 5.3 kW/kg), and low moisture content.

**IMPORTANT:** Pellets must be stored in a dry place. Use only good quality pellets, without sawdust.

**IMPORTANT NOTICE:** The small quantities of sawdust normally present at the bottom of the bags should not be emptied into the tank, but should be held inside the bag while pouring the pellets carefully so that the sawdust remains inside.

If sawdust accumulates in the tank, it should be removed periodically with a vacuum cleaner (with the door open and disconnecting the power plug from the electricity supply), to prevent it entering the loading system and causing serious malfunctions.

**IMPORTANT:** If, during a loading operation, or for any other reason, foreign matter is allowed to enter the tank and then the pellet loader, it may cause damage to the internal mechanisms.

Besides causing damage, this would cause the stove to stop. In this case, the manufacturer cannot accept any liability.

### **ONLY 6mm DIAMETER PELLETS MUST BE USED**

**DO NOT USE POOR QUALITY PELLETS OR RE-PROCESSED PELLETS WITH HIGH SAWDUST CONTENT. THIS TYPE OF PELLETS CAN SERIOUSLY IMPAIR THE FUNCTIONS IN YOUR STOVE, VOID THE WARRANTY AND THEREFORE RELEASE THE MANUFACTURER FROM ALL LIABILITY.**

### PELLET LOADING

The pellet tank capacity is 25 Kg.

To load, lift the pellet tank lid, and pour in the pellets, taking care to keep any sawdust inside the bags.

Close the lid when loading is complete.

**IMPORTANT: LOADING MUST BE CARRIED OUT ONLY WHEN THE STOVE IS OFF AND HAS COOLED DOWN.**

Fig.9



When pellets are used up, the stove cannot work and is therefore locked out, the display shows **“ALARM NO FIRE”**.

When refilling with pellet at this point it will take a little while for the pellet to come through so the fire may go to lockout again. This is normal and will light normally once the pellet has started to feed, probably at the second attempt.

### NOTES ON OPERATION

Description of front panel controls

Button 4: ON/OFF and exit programming mode

Button 3: press once to change temperature settings, then button 1 to raise and 2 to lower.

Buttons 5 and 6: UP/DOWN for thermal power setting

Buttons 2 and 1: UP/DOWN for temperature setting, programming functions and indicators

#### *Upper LED display*

Top left: timer program active

Bottom right: pellet auger ON

Top right: (not active)

Bottom left: this will flash when stove is cooling after being lit. Wait until this lamp goes out before restarting.

#### *Lower LED display*

Top left: heating elements ON

Top right: thermostat ON (set temperature achieved)

---

### Operation:

To start the stove, press button 4; after a few moments, the control unit puts the stove into the pre-ignition phase, lighting the igniter plug and showing the message "**FAN CAND**" on the display; it also switches the extractor fan on at maximum power for about 5 seconds, then brings it down to ignition power.

After this phase (which lasts about 90 seconds), the message "**LOAD WOOD**" appears on the display and the auger loads the pellets at the pre-set speed.

When the smoke temperature reaches the ignition value set by the manufacturer, the stove goes into stabilization phase and shows the message "**FIRE ON**" on the display. It then switches off the igniter plug.

The room air fan for the heat exchanger also starts up during the stabilisation phase and may run fast for a short time.

When this phase is complete, the control unit goes into working mode, in which the display shows the selected thermal power value (set by buttons 5 and 6) and ambient temperature.

In this phase, buttons 5 and 6 can be used to set the power output of the stove from 1 to 5, provided that room temperature is below the set value, otherwise power is reduced to minimum value.

If the pellets are not lit within 15 min., the stove displays the message "**ALARM NO FIRE**". This is normal at first start up or if the auger has run out of pellet. Switch off and on again to reset. Make sure there is pellet in the hopper.

If there is an electrical power failure, when power is restored, the stove expels the remaining smoke and resumes the working program from the point at which it stopped. It can do this only if the electrical power was lost for a few minutes. If the stove has cooled down during the power failure, the control unit puts the stove back into the ignition phase, and re-starts the program from the beginning.

To change the temperature setting at any time, simply press button 3 and use buttons 2 and 1 to adjust the temperature shown on the lower display. During the operating phase, the lower display indicates ambient temperature.

When the room temperature is reached, the stove changes from the working program into **ECO mode (pilot flame)**. **ECO mode is the same power as heat setting 1**. When ambient temperature falls by **2°C**, the stove goes back into working mode.

When not in setting mode, button 1 can be pressed to show the smoke temperature on the lower display.

The stove can be switched off by pressing button 4; in this case, the word **OFF** appears on the upper display, pellet flow is stopped and extractor fan speed increases. When cooling is complete, the ventilator (exchanger) is switched off and, after several minutes, the extractor fan is also switched off.

**N.B.:** when the stove is cooling, the fan is working for several minutes.

### OPERATING SEQUENCE AND SWITCHING OFF

To start or stop the stove press button 4 on the control panel. On starting, the message **FAN CAND** is displayed for 1.5 minutes and then the message **LOAD WOOD** appears for 4-5 minutes. During this time the burn pot will be lit and the flame stabilised. Finally the message **FIRE ON** appears for 3 minutes. The starting time takes about 10 minutes. During this initial phase, the display shows the working programme and can be modified using buttons 5 and 6 on the control panel. To set the desired room temperature use buttons 1 and 2. When the programming phase is complete the stove continues working until the selected room temperature is reached, then the stove goes into **ECO** mode (small pilot flame).

Press button 3, **SET** to page through the timer programming functions and to confirm the selection. Pressing button 4 **ON/OFF** will exit programming mode at any time.



Display Shows	Action
<b>UT01</b>	Set the current day. If today is Monday then using buttons 1 & 2 set to DAY 1. If Wednesday, set to DAY 3.
<b>UT02</b>	Current clock time in hours using 24 hour clock. (4pm = 16)
<b>UT03</b>	Current clock time in minutes (0-59)
<b>UT04</b>	Not used
<b>UT05</b>	ON time (first event setting)
<b>UT06</b>	OFF time (first event setting)
<b>UT07</b>	Day for programme to run. For Monday to Friday working, set Day 1 ON, Day 2 ON, Day 3 ON, Day 4 ON, Day 5 ON and Day 6 OFF, Day 7 OFF. The stove will not function on Saturday and Sunday. To only run on Saturday/Sunday set Days 1-5 to OFF and Days 6-7 to ON.
<b>UT08</b>	ON time (Second event setting)
<b>UT09</b>	OFF time (Second event setting)
<b>UT10</b>	Day for programme to run (As UT07)

If it is required for the stove to run all day using only one event from say 0800 to 2000 then set **UT05** to 0800 and **UT06** to 2000. Select the day using **UT07**. At UT10 set all days used at **UT07** to off. When using two event programming allow at least 30 minutes between the end of the first event to the start of the second event.

If the stove is not required to work automatically set **UT01** to OFF. In this case the stove ignores all other settings and will maintain the set room temperature. If the remote thermostat is connected this will take priority for the temperature setting.

When the stove is off, pressing and holding button 1 or 2 will show the heat setting of the stove when lit. This will either display **ECO** if the room temperature is at or above the set temperature or the heat setting 1-5 as previously set.

If the flue gas temperature rises above 260°C, the stove goes into economy mode and the message **ECO** is displayed. This message is also displayed when the selected room temperature has been reached.

## ELECTRONIC CONTROL PANEL

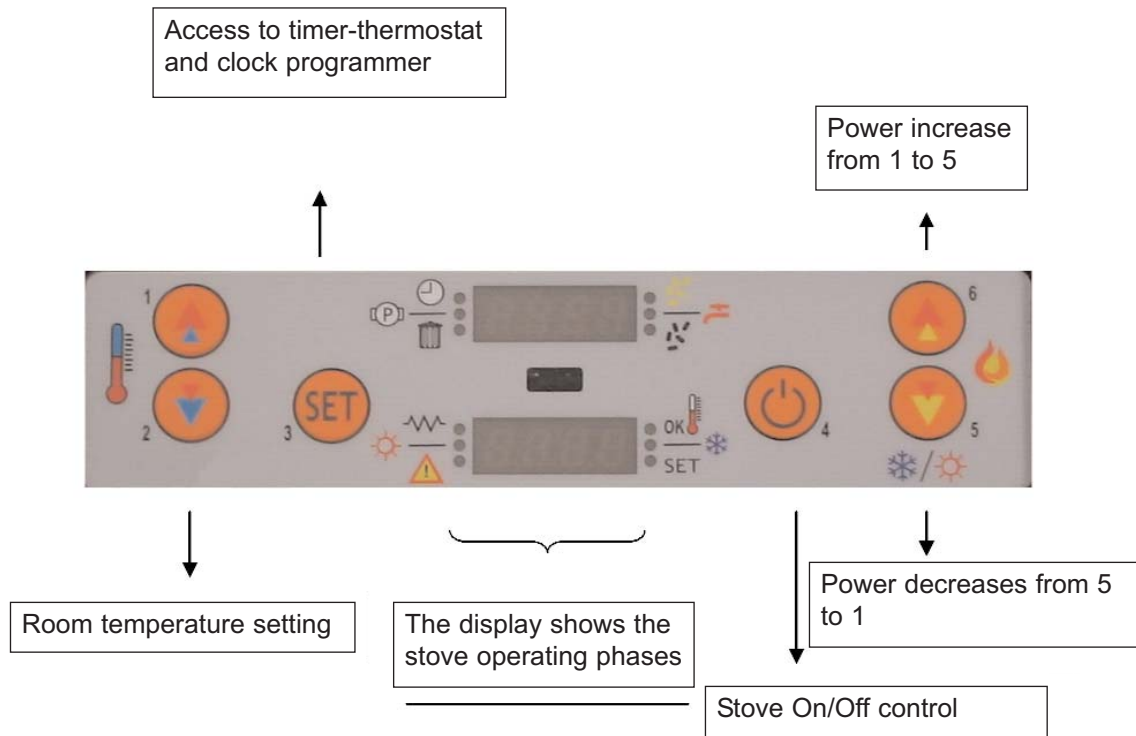

## REMOTE CONTROL FUNCTIONS (optional)

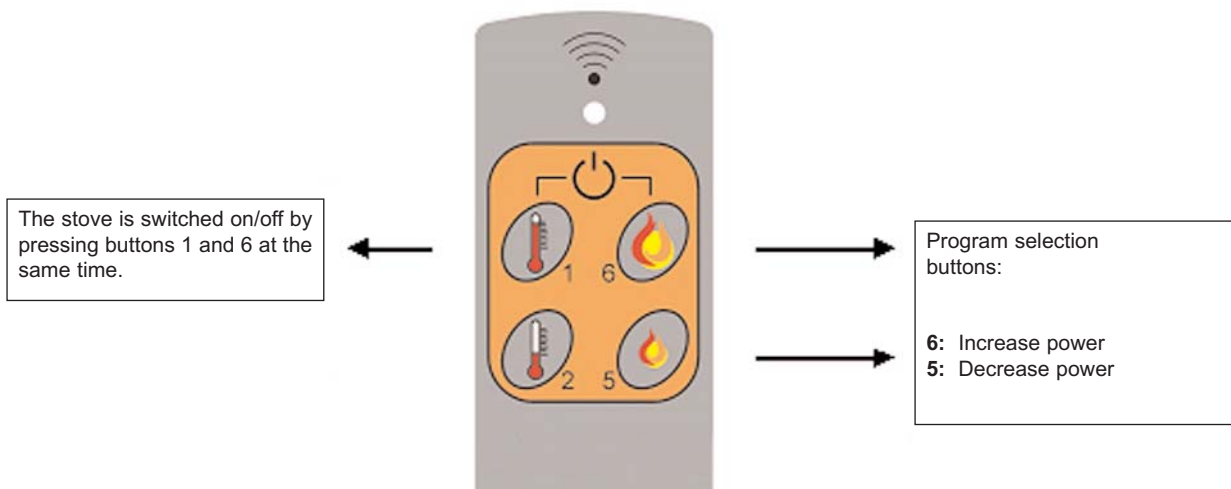

# CIRCUIT BOARD WIRING DIAGRAM

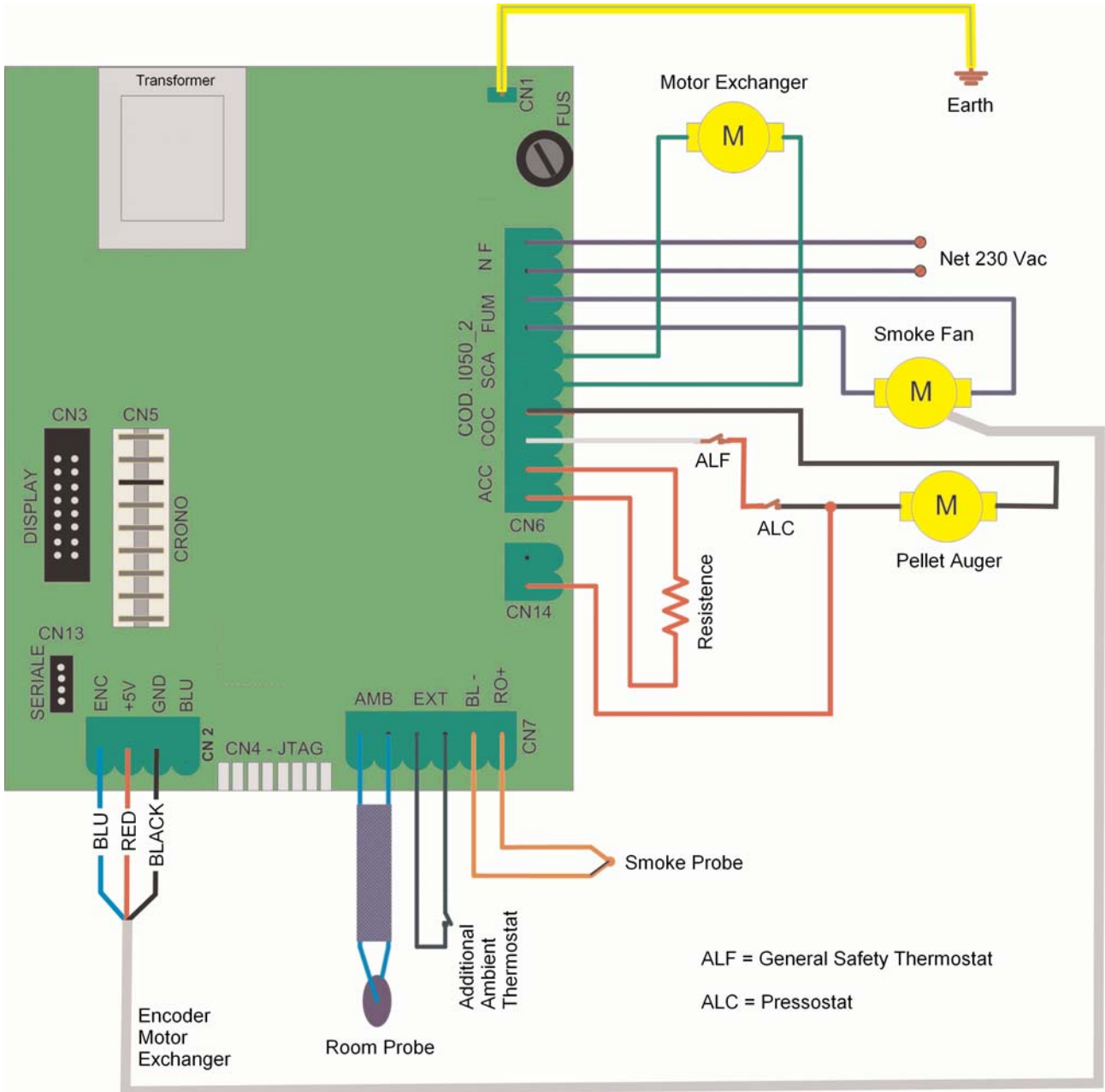

## MANAGING ALARMS

An alarm indication may appear in one of the following cases (the alarm can be cleared by pressing button 4 "ON OFF"):

- Flue gas temperature probe alarm 

ALARM
SOND FUMI

If there is a fault in the flue gas temperature probe, the message "ALARM SOND FUMI" appears and the ventilator and extractor fan are switched on at maximum speed.

- Flue gas over-temperature alarm 

ALARM
HOT TEMP

If the flue gas temperature rises above 280° C, the message "ALARM HOT TEMP" appears and ventilator and extractor fan remain lit until the decrease of flue temperature.

- Ignition failure alarm 

ALARM
NO FIRE

- Extractor alarm (if this option is available)

This appears if the initial attempt to ignite has failed, or if stove temperature is too low for operation, even after the full ignition period has elapsed. The message "ALARM NO FIRE" is displayed and the extractor fan runs for a pre-set time until the stove is completely switched off.

- Pressostat alarm 

ALARM
DEP FAIL

Incase the exchanger gets dirty or the chimney is obstructed, the safety pressostat switches the motor auger off (stops the fuel).

**In certain weather conditions, the Pressostat switch can operate even if there is no malfunction of the stove. This can be caused by a low flue draught. This is a normal event. There is no problem with the stove. If the problem persists check the flue for gas tightness and draught.**

- Safety thermostat alarm 

ALARM
SIC FAIL

In case of high stove temperature, the safety thermostat operates and shows on the display the following notice: "ALARM TERM SICC". To restart the stove, wait until cool and reset it as shown in Fig 10.

Fig.10

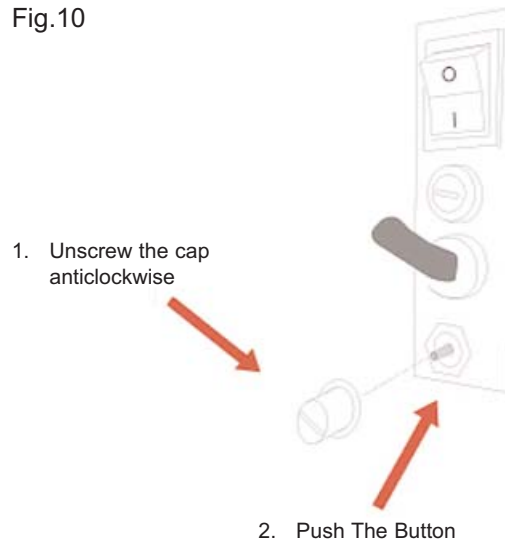

**ATTENTION: the thermostat has to be reset by hand.**

**The control panel is situated in the lower rear part of the stove.**

**N.B. the thermostat does not unlock until the stove has cooled completely.**

If the thermostat reset has been successful, a click can be heard immediately. Also refer to Safety Devices Section 4 page 13. Before every new ignition, verify that the burn pot is completely empty; if not, clean it immediately.

**The alarm signals can be cancelled by switching off and on the stove with button No.4 situated in the frontal panel of the stove.**

**Ensure Air Inlet and flue gas outlet are clear from obstructions before operation of the stove.**

If the flue gas temperature rises above 260°C, the stove goes into Economy mode and the message 

ECO
-----

 appears on the display.

The message 

ECO
-----

 also appears when the selected room temperature has been reached.

## SWITCHING OFF

The stove can be switched off in different ways:

1. Manually (putting the On/Off switch on the back of the stove in the Off position).
2. By actuation of a room thermostat, if this is connected.
3. By a timer program.
4. Using the remote control (if this option is available).

---

**N.B.:** Method 1 is used to carry out maintenance or to switch off the stove permanently at the end of the cold season. Never switch off the stove while it is in operation, either by cutting off the current at the plug or at the switch located on the back of the stove.

This will cause the smoke extractor fan to stop immediately, causing smoke to issue into the room if there is no natural upward draught in the chimney.

**After switching off the stove on the front panel, or using the remote control (if this option is present), wait for 15 minutes cooling time to elapse before attempting to start again. The stove may not re-light if it has not cooled sufficiently.**

During the switch-off phase, the smoke extraction motor continues to run until the stove is cooled, then switches off automatically. Similarly, the room air ventilator continues running until the stove has cooled (the ventilator may switch off and then on again if there is still some heat in the stove).

## **SAFETY DEVICES**

### **1. Flue Gas Extraction Motor Failure**

If the flue gas extractor stops, a pressure switch immediately stops the pellet supply.

### **2. Flue Gas Outlet Safety Device**

If the flue gas outlet is obstructed, the pressure switch prevents fuel from entering the burn pot.

### **3. Pellet Loading Gear Motor Failure Or Blockage**

If the gear motor stops, the stove continues to operate until it starts to cool down. The system will attempt to start up the stove, and if the fault persists the stove will stop completely and lock out.

### **4. Hot Air Distribution Ventilator Failure**

When the temperature at the end of the loader reaches 105°C, a safety thermostat stops the gear motor, causing the stove to switch off.

If the thermostat is activated, it must be reset using the special control (protected by a screw plug) on the back of the stove under the main switch and protection fuse.

**If the thermostat is actuated again and causes the stove to stop, contact the technical support service immediately.**

## **5. Temporary Electrical Power Failure**

If there is a temporary power failure while the stove is in operation, the appliance will come on again automatically. If the power failure is longer lasting, the smoke extractor stops running and the stove may therefore emit smoke into the room.

## **6. Electrical Safety**

The stove is protected by a main fuse located on the rear panel.

## **CLEANING OF THE STOVE**

**IMPORTANT:** before starting to clean the stove, check that it is switched off and completely cooled and that the electrical power supply is disconnected.

## **ASHPAN AND BURN POT**

**WARNING: Do not vacuum hot cinders as they may cause a fire in the cleaner.**

The burn pot must be cleaned everyday. Pull it out manually by lifting, and empty the accumulated ash. When re-inserting the burn pot, check that it is the right way around, with the hole for the igniter plug facing towards the inside of the stove.

Every two or three days, clear the grid at the bottom of the combustion chamber, take out the drawer, empty it and replace in the correct position. Finish off cleaning the inside of the chamber using a vacuum cleaner. We recommend emptying the lower ashpan periodically, as described in the following paragraphs. It may be necessary to vacuum the small chamber beneath the burn pot.

**IMPORTANT:** All cleaning and maintenance operations must be carried out when the stove is cold. These cleaning operations ensure that the appliance continues to work efficiently and correctly. The required frequency of cleaning operations depends very much on the quality of the pellets used. We recommend using only tested, good-quality pellets.

After the cold season has ended, the exchanger must be cleaned. This operation may be required more often, depending on the pellet quality, but this should not be considered a sign that the stove is not functioning correctly.

## **CLEANING THE ASHPAN**

Open the panel, remove the ashpan, empty it and re-insert correctly. This operation is usually carried out once per week, and more often if required.

Fig.11

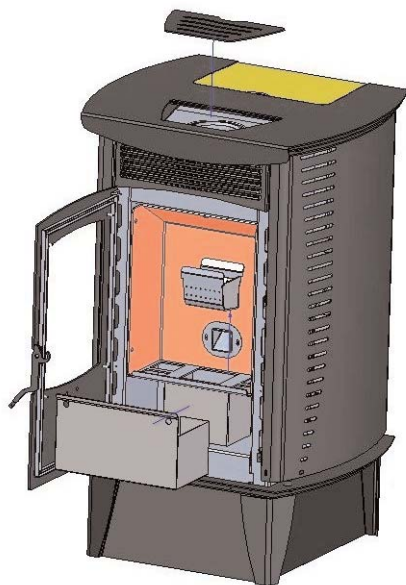

## END OF SEASON

We advise using up all pellets remaining in the tank in order to prevent condensation from forming and thus clogging and blocking the feeder motor.

Pellets and sawdust remaining at the bottom of the tank should be removed using a vacuum cleaner. If there are substantial amounts of sawdust, we recommend checking the quality of the pellets used to fuel the stove.

This operation is carried out with the stove off and cool, and the power supply plug disconnected.

**CAUTION: Do not vacuum hot cinders as they may cause a fire in the vacuum cleaner.**

## GLASS

The glass will self clean when there is sufficient heat generated by the burning fuel. If a build-up of deposits occur on the glass it may be due to draft conditions, poor quality fuel or very low burning for a long time. It is best to clean the glass when it is thoroughly cooled. A deposit of ash will usually wipe away with a dry cloth.

## PERIODIC CLEANING OF THE STOVE AND HEAT EXCHANGER

The stove and heat exchanger must be cleaned periodically, and exclusively by authorised personnel. You should therefore call the technical support service.

We suggest you carry out this operation after the cold season has finished.

## CLEANING THE FLUE

Whenever this is found to be necessary (and at least once a year) vacuum and clean all flue ducts to prevent the build up of particulate matter. It is important not to obstruct the passage of the flue gasses.

**IMPORTANT:** Ensure that the flue pipe gaskets are gas tight. Where they are not in good condition replace them immediately. Do not use flexible flue pipe.

**FAILURE TO CLEAN THE FLUE MAY AFFECT THE SAFE OPERATION OF THE STOVE.**

## PROBLEMS - CAUSES - SOLUTIONS

PROBLEM / CAUSE	SOLUTION
<b>Problem</b>	Pellets not delivered into burn pot
<b>Causes</b>	<ul style="list-style-type: none"> <li>* Tank is empty</li> <li>* Flue gas extractor fan is not working</li> <li>* Auger blocked by foreign objects</li> <li>* No electrical power to control panel</li> <li>* Flue obstructed causing differential pressure switch lock out</li> </ul>
<b>Solutions</b>	<ul style="list-style-type: none"> <li>* Re-fill the tank</li> <li>* Call technical support service</li> <li>* Call technical support service</li> <li>* Check that the power plug is correctly inserted and that the fuse is good</li> <li>* Clean all the smoke outlet pipe and flue</li> </ul>
<b>Problem</b>	When switched on, the stove functions for a few minutes then is switched off by a safety device.
<b>Cause</b>	The outlet fumes are not reaching the minimum temperature required to switch off the igniter.
<b>Solution</b>	Check that the burn pot is clean
<b>Problem</b>	Flame is too smoky
<b>Causes</b>	<ul style="list-style-type: none"> <li>* Insufficient combustion air as the air holes in the burn pot are obstructed</li> <li>* Flue obstructed or clogged.</li> <li>* Stove and exchanger dirty</li> <li>* Pellets are poor quality or contain too much moisture.</li> </ul>
<b>Solutions</b>	<ul style="list-style-type: none"> <li>* Clean the burn pot</li> <li>* Clean the flue gas outlet pipe and flue</li> <li>* Clean the exchanger</li> <li>* Replace the pellets</li> </ul>
<b>Problem</b>	Flame does not ignite
<b>Causes</b>	<ul style="list-style-type: none"> <li>* Air inlet clogged</li> <li>* Ash present in the burn pot</li> <li>* Pellets used up</li> <li>* Differential pressure switch activated</li> </ul>
<b>Solutions</b>	<ul style="list-style-type: none"> <li>* Check that the air inlet is clean and not obstructed</li> <li>* Clean the burn pot</li> <li>* Re-fill the tank</li> <li>* Clean the flue gas outlet pipe and flue or close main door</li> </ul>

<b>PROBLEM / CAUSE</b>	<b>SOLUTION</b>
<b>Problem</b>	Pellet loader blocked
<b>Causes</b>	Poor quality pellets, sawdust included accidentally or pellet stuck and obstructing the feeder slide to the burner, possibly causing the loading auger to become blocked.
<b>Solutions</b>	The problem can often be resolved without calling technical support, simply by inserting a flexible steel rod inside the pellet loading tube once the stove is off and has cooled. In this way, the blocked pellet can be made to fall into the burn pot, thus unblocking the auger. This operation is carried out with the stove off and the power supply plug disconnected.
<b>Problem</b>	While the stove is in operation, the pellet loading indicator light comes on, but no pellets fall into the burn pot.
<b>Cause</b>	<ul style="list-style-type: none"> <li>* Air exchanger ventilator dirty</li> <li>* Air exchanger ventilator broken</li> <li>* Stove overheating and safety thermostat was activated</li> <li>* Flue obstructed or draught diverter grill clogged</li> </ul>
<b>Solution</b>	<ul style="list-style-type: none"> <li>* Call technical support service</li> <li>* Call technical support service</li> <li>* Call technical support service</li> <li>* Clean the whole flue - remove draught diverter and grill</li> </ul>

**If the problem cannot be resolved, please contact the Installer.**



## FUSION PELLET STOVE TECHNICAL DETAILS

Max. fuel consumption per hour	kg/h	2.9	
Maximum input	kW	14.4	
Minimum input	kW	4.4	
Maximum output	kW	13.0	
Minimum output	kW	4.1	
Efficiency	%	90.4	
Minimum air requirement for combustion	m <sup>3</sup> /h	33	
Flue gas mass flow rate	gr/s	9.4	
Flue gas temperature	maximum power	°C	155
	minimum power	°C	75
Minimum draught of fireplace	mbar	0.1	
	pascal	10	
Elect. power consumption during ignition*	W	260	
Elect. power consumption during operation	W	91	
Power Supply	V/Hz	230/50	
Width	mm	590	
Height	mm	1050	
Depth	mm	540	
Net weight	kg	115	
Pellet tank capacity	kg	25	
Total Weight	kg	140	
Diameter of flue gas outlet	mm	80	
Diameter of combustion air inlet pipe	mm	30	
Features			
Flue outlet pressure switch			
Ashpan			
Self-cleaning glass			
Forced ventilation			
Adjustable feet			
Pre-equipped for connection to room thermostat			
<small>* Power consumption during first 10 minutes of operation</small>			

**Aga,**  
Station Road,  
Ketley, Telford,  
Shropshire, TF1 5AQ,  
UK

