



AGA CITY24 (Gas Hob) USA/CAN

AGA CITY60 (Gas Hob) AUS

LPG CONVERSION INSTRUCTIONS (KIT PART NO. AG1M251670) USA/CAN

INSTRUCTIONS POUR CONVERSION GPL (KIT RÉF. AG1M251670) CAN/FR

LPG CONVERSION INSTRUCTIONS (KIT PART NO. AG1M251752) AUS

REMEMBER, when replacing a part on this appliance, use only spare parts that you can be assured conform to the safety and performance specification that we require.

DO NOT use reconditioned or copy parts that have not been clearly authorised by AGA.

RAPPEL : si vous avez besoin de remplacer certaines pièces sur cet appareil, n'utilisez que des pièces conformes à nos spécifications de sécurité et de performance.

N'UTILISEZ PAS de pièces reconditionnées ni de copies n'ayant pas été spécifiquement autorisées par AGA.

PLEASE READ THESE INSTRUCTIONS AND KEEP IN A SAFE PLACE FOR FUTURE REFERENCE.

VEUILLEZ LIRE LES INSTRUCTIONS ET CONSERVER LE MANUEL AFIN DE POUVOIR LE CONSULTER PLUS TARD.

For use in USA, CANADA and AUSTRALIA
Destiné à une utilisation en USA, CANADA et AUSTRALIA

06/17 EINS 517429

Contents

AGA City24 Gas Hob (USA/CAN) 1

**AGA City24 Cuisinière au gaz
(FR/CAN) 4**

AGA City60 Gas Hob (AUS) 7

AGA City24 Gas Hob (USA/CAN)

WARNING SERVICING TO BE CARRIED OUT ONLY BY AN AUTHORISED PERSON.

Disconnect from electricity and gas before servicing. Check appliance is safe when you have finished.

Check the 'Technical Data' section, that the hob is convertible to the gas you want to use.

A suitably competent person must perform the conversion. After conversion the installation must comply with the relevant regulations and also the local electricity supply company requirements. Read the instructions before converting this appliance.

- ⚠ Failure to convert the appliance correctly could invalidate any warranty or liability claims and lead to prosecution.**
- ⚠ When servicing or replacing gas carrying components disconnect from the gas supply before starting operation. Check the appliance is gas sound after completion.**
- ⚠ DO NOT use reconditioned or unauthorised gas controls.**
- ⚠ Disconnect from the electricity and gas supply before servicing.**
- ⚠ Before electrical reconnection, check that the appliance is electrically safe.**

Injectors

Remove the burner caps and flame spreaders. Remove the old jets. Fit the new jets (see 'Technical Data' section for the correct jets). Reassemble in the reverse order. (See **Fig. 1.1**, **Fig. 1.2** and **Fig. 1.3**).

Bypass Screw Adjustment

Pull off all the control knobs and bezels. Turn the bypass screw on each control clockwise to the stop (See **Fig. 1.4**).

Gas Regulator applies to USA / Canada

The gas regulator, located on the right hand side of the cooker (see **Fig. 1.5**), is pre-set for Nat. Gas. Remove the cap from the regulator, pull the plastic insert from the cap, turn and re-locate it into the cap as shown (see **Fig. 1.6**). Replace the cap.

Stick on Label

Stick the LP gas label over the natural gas part of the appliance data label.

Pressure Testing

Connect the appliance to the gas supply.

The pressure test point is situated just below hotplate level on the rear right hand side of the cooker.

Place the wok burner head, burner cap and ring into position on the hotplate. Light the burner by pushing in the appropriate control knob and turning it anticlockwise to the FULL ON position (large flame symbol).

For **Natural Gas** appliances, the manifold pressure should be 4 inches water gauge

For **LPG** appliances, the manifold pressure should be 10 inches water gauge.

Turn off the tap, disconnect the pressure gauge and refit test point blanking screw.

Check operation of all the burners.

Check for gas tightness.

Assembly of burners and adjustment

FITTING BURNER CAP - RAPID AND SEMI-RAPID BURNERS

PLACE BURNER CAP OVER RETAINING LUGS, THEN TURN CAP CLOCKWISE TO LOCK INTO POSITION.

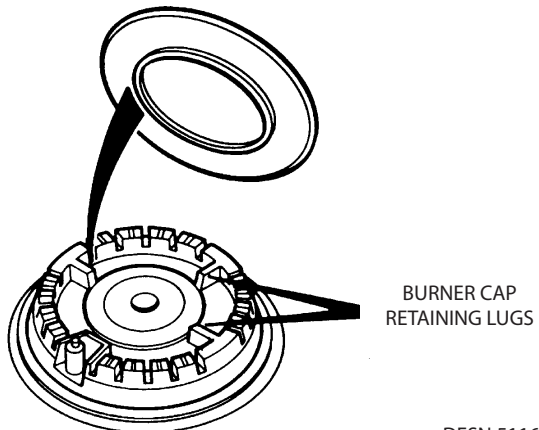

Fig. 1.1

DESN 511617

ASSEMBLY OF RAPID AND SEMI-RAPID BURNERS

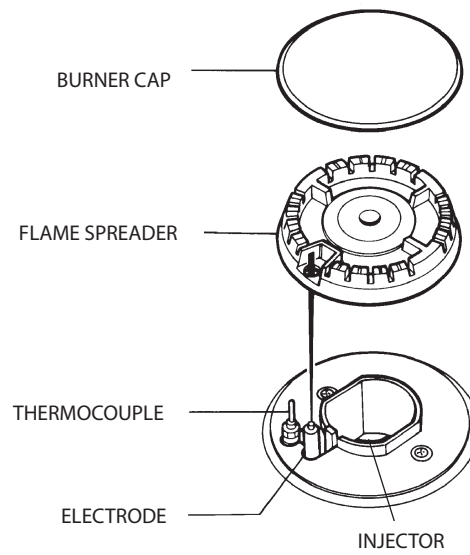

Fig. 1.2

DESN 513513

WOK BURNER

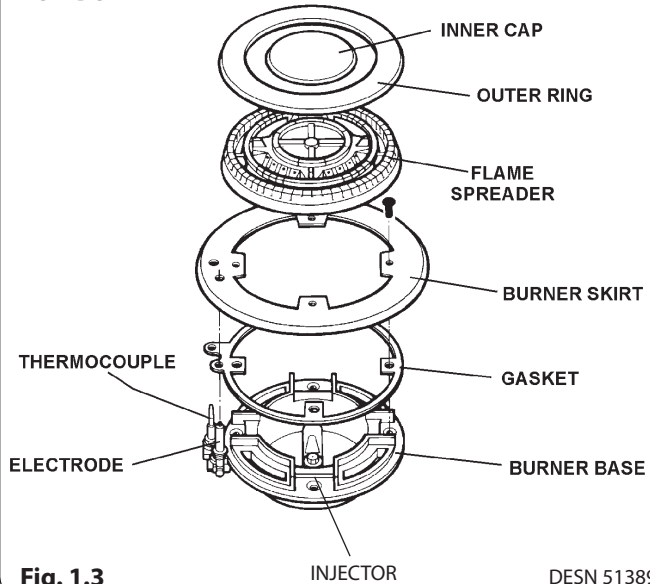

Fig. 1.3

DESN 513898

BYPASS SCREW

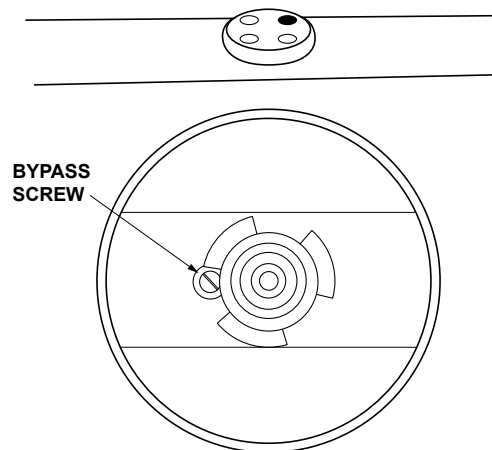

Fig. 1.4

GAS REGULATOR

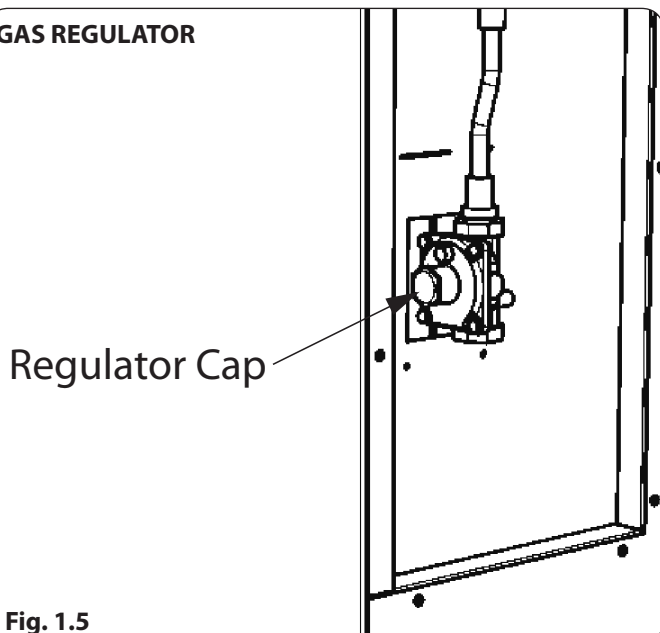

Fig. 1.5

REGULATOR CAP

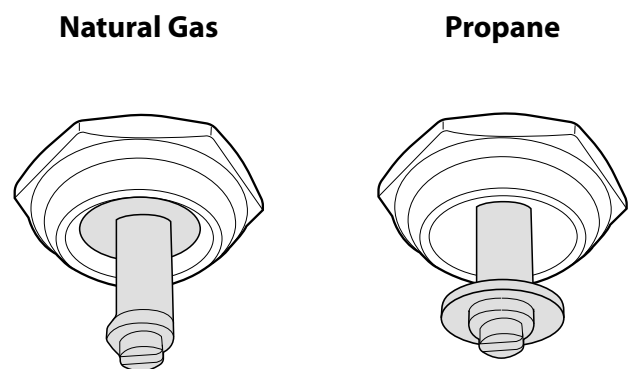

Fig. 1.6

Technical data

GAS TOP BURNERS

This appliance is supplied set for Natural Gas (NG) at a pressure of 4" WC. It must be converted to run on LP Gas (Propane) at a pressure of 10" WC.

NATURAL GAS	Left-hand Front	Right-hand Rear	Left-hand Rear	Right-hand Front
Burner Type	Ultra-rapid (WOK)	Rapid	Semi-rapid	Semi-rapid
Maximum Heat Input	3.5 kW 12,000 Btu/hr	3.1 kW 10,600 Btu/hr	1.8 kW 6,150 Btu/hr	1.8 kW 6,150 Btu/hr
Injector Marking	170	155	118	118
Pressure Point Position	Just below hotplate level, on the rear right hand side of the range.			
Pressure Setting	4" w.g.			
Burner Ignition	H. T. Spark			

PROPANE	Left-hand Front	Right-hand Rear	Left-hand Rear	Right-hand Front
Burner Type	Ultra-rapid (WOK)	Rapid	Semi-rapid	Semi-rapid
Maximum Heat Input	3.5 kW 12,000 Btu/hr (250 g/h) (0.5 l/h)	3.1 kW 10,600 Btu/hr (221 g/h) (0.43 l/h)	1.8 kW 6,150 Btu/hr (128 g/h) (0.26 l/h)	1.8 kW 6,150 Btu/hr (128 g/h) (0.26 l/h)
Injector Marking	105	94	72	72

Pressure Point Position	Just below hotplate level, on the rear right hand side of the range.
Pressure Setting	10" w.g.
Burner Ignition	H. T. Spark
Electric Ovens	240 V 60 Hz Single Phase 30 AMP
Top Oven Power Rating	3.0 kW
Lower Oven Power Rating	0.9 kW

The data plate is located on a pull-out plate behind the plinth cover.

Typical section view of burner flames

L.H.F. Hotplate Burner

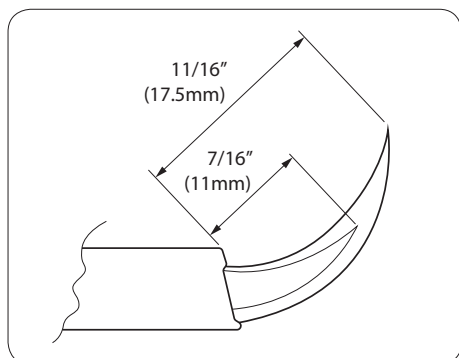

R.H.R. Hotplate Burner

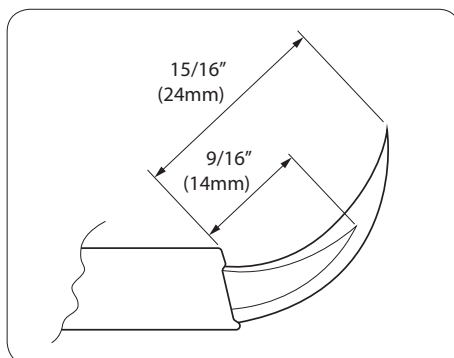

L.H.R. and R.H.F. Hotplate Burner

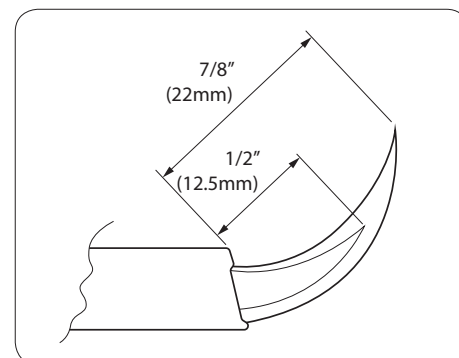

AGA City24 Cuisinière au gaz (FR/CAN)

**AVERTISSEMENT L'ENTRETIEN DOIT ÊTRE EFFECTUÉE PAR UNE PERSONNE COMPÉTENTE ET HABILITÉE.
DÉBRANCHEZ DE L'ALIMENTATION EN ÉLECTRICITÉ ET DU GAZ AVANT D'EFFECTUER L'ENTRETIEN.
ASSUREZVOUS QUE L'APPAREIL EST SANS DANGER LORSQUE VOUS AVEZ TERMINÉ.**

Consultez la section « Données techniques » et pour vous assurer que.

Une personne dûment qualifiée doit effectuer la conversion. Après la conversion, l'installation doit être conforme avec les réglementations pertinentes de même que les exigences locales des entreprises en approvisionnement en électricité. Veuillez lire les instructions avant de convertir cet appareil.

- ⚠ Le nonrespect de convertir correctement cet appareil annule toute garantie ou toute responsabilité entraînant des poursuites judiciaires.**
- ⚠ Lors de l'entretien ou du remplacement de composants de conduite en gaz, débranchez l'appareil de l'approvisionnement en gaz avant de commencer la mise en service. Assurezvous que l'appareil est salubre de gaz après l'achèvement.**
- ⚠ NE PAS utiliser de contrôles de gaz remis à neuf ou non autorisés.**
- ⚠ Débranchez de l'approvisionnement électrique et en gaz avant l'entretien.**
- ⚠ Assurezvous que l'appareil est électriquement sans danger avant la reconnexion électrique.**

Injecteurs

Enlevez les couvercles de brûleur et les épandeurs de flamme. Enlevez les anciens jets. Ajustez les nouveaux jets (consultez la section « Données techniques » pour les jets appropriés). Remontez dans le sens inverse. (Voir **Fig. 1.7**, **Fig. 1.8** et **Fig. 1.9**).

Ajustement de la vis de dérivation

Retirez tous les boutons de contrôle et les enjoliveurs. Sur chaque contrôle, tournez la vis de dérivation dans le sens des aiguilles d'une montre jusqu'à l'arrêt (voir **Fig. 1.10**).

Régulateur de gaz (Etats-Unis / Canada uniquement)

Le régulateur de gaz, situé sur le côté droit de la cuisinière (voir **Fig. 1.11**), est pré-réglée pour Nat. Gaz. Retirez le bouchon du régulateur, tirez l'insert en plastique du bouchon, tourner et re-localiser dans le bouchon comme indiqué (voir **Fig. 1.12**). Remettre le bouchon.

Malade sur L'étiquette

Coller l'étiquette de gaz propane sur la partie du gaz naturel de l'étiquette de données de l'appareil.

Test de pression

Branchez l'appareil à l'approvisionnement en gaz.

Le point de test de pression est situé juste sous le niveau de la plaque de cuisson sur le côté droit arrière du cuiseur.

Placez la tête de brûleur pour wok, le couvercle de brûleur et la bague en position sur la plaque de cuisson. Allumez le brûleur en poussant le bouton de contrôle approprié et en le tournant dans le sens inverse des aiguilles d'une montre dans la position « FULL ON » (symbole d'une large flamme).

Pour les appareils au **gaz naturel**, la pression doit être de 20mbar (indicateur de niveau d'eau à 20.3 cm (8 pouces)).

Pour les appareils au **gaz de pétrole liquéfié (gaz LP)**, la pression doit être de G30/28 mbar ou G31/37mbar.

Fermez le robinet, débranchez le manomètre et réajustez le point de test de la vis d'obturation.

Vérifiez le fonctionnement de tous les brûleurs.

Vérifiez l'étanchéité au gaz.

Assemblage des brûleurs

Ajuster les couvercles de brûleur - brûleurs rapides et semirapides

Placez le couvercle de brûleur par dessus les ergots de fixation et tournez ensuite le couvercle dans le sens des aiguilles d'une montre pour verrouiller en position.

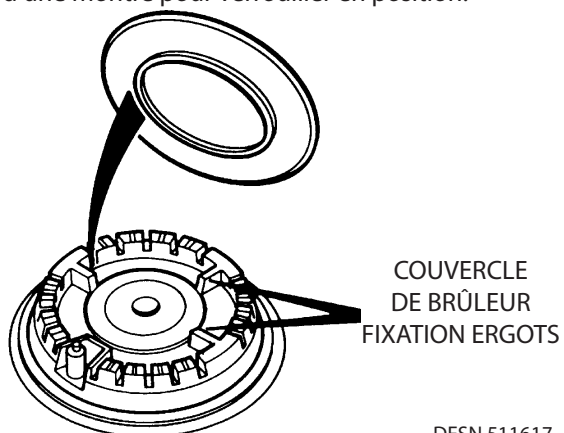

Fig. 1.7

DESN 511617

ASSEMBLAGE DES BRÛLEURS RAPIDES ET SEMI-RAPIDES

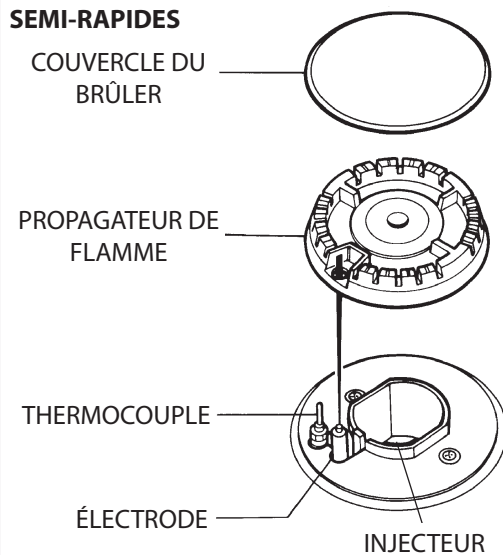

Fig. 1.8

DESN 513513

BRÛLEUR POUR WOK

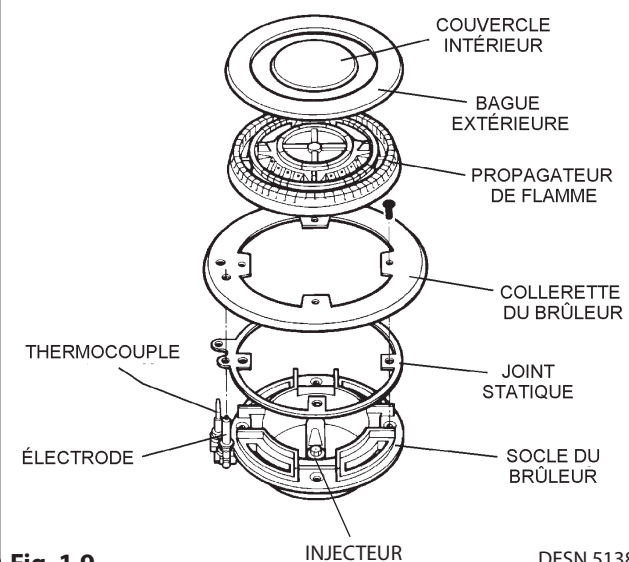

Fig. 1.9

DESN 513898

VIS DE DÉRIVATION

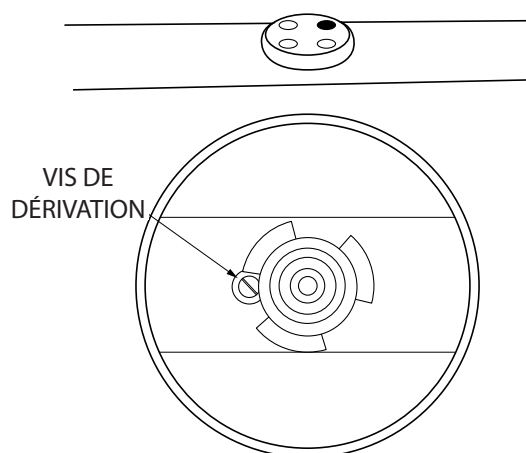

Fig. 1.10

GAZ REGULATEUR

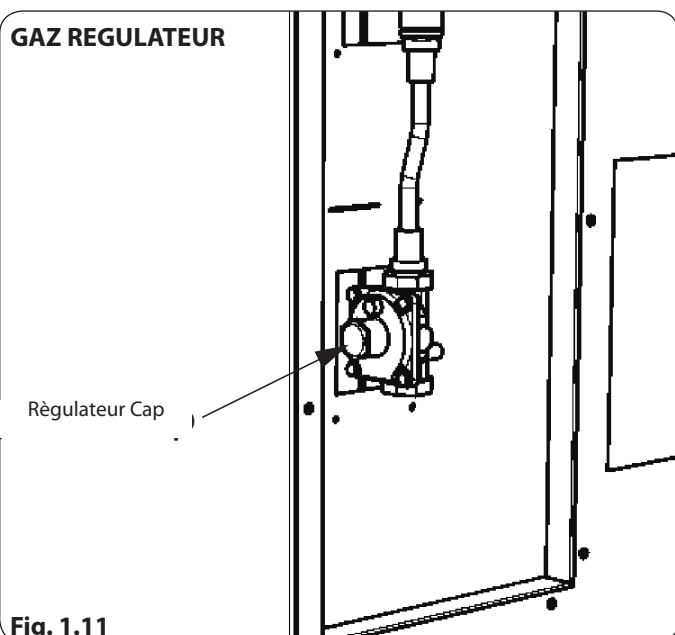

Fig. 1.11

REGULATEUR CAP

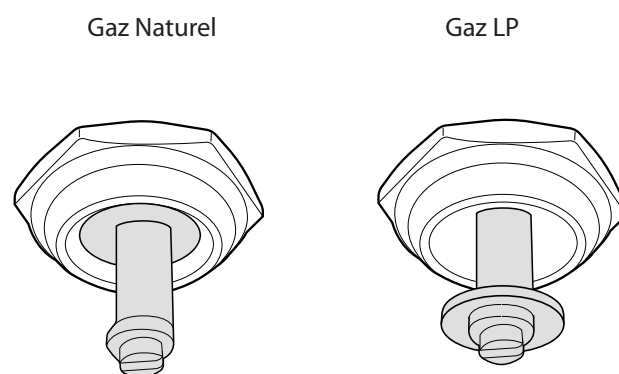

Fig. 1.12

Données techniques

BRÛLEURS AU GAZ SUR LE DESSUS

GAZ NATUREL				
	Gauche-Avant	Droit-Arrière	Gauche-Arrière	Droit-Avant
Type de Brûler	Ultra-rapide (WOK)	Rapide	Semi-rapide	Semi-rapide
Type de Maximale Entrée	3.5 kW 12,000 Btu/hr	3.1 kW 10,600 Btu/hr	1.8 kW 6,150 Btu/hr	1.8 kW 6,150 Btu/hr
Marquage D'injecteur	170	155	118	118
Position de Point de pression	Juste sous le niveau de la plaque de cuisson du côté arrière droit de la cuisinière			
Configuration de pressiom	4" de colonne d'eau			
Allumage Du Brûleur	H. T. Étincelle			

PROPANE				
	Gauche-Avant	Droit-Arrière	Gauche-Arrière	Droit-Avant
Type de Brûler	Ultra-rapide (WOK)	Rapide	Semi-rapide	Semi-rapide
Type de Maximale Entrée	3.5 kW 12,000 Btu/hr (250 g/h) (0.5 l/h)	3.1 kW 10,600 Btu/hr (221 g/h) (0.43 l/h)	1.8 kW 6,150 Btu/hr (128 g/h) (0.26 l/h)	1.8 kW 6,150 Btu/hr (128 g/h) (0.26 l/h)
Marquage D'injecteur	105	94	72	72

Position de Point de pression	Juste sous le niveau de la plaque de cuisson du côté arrière droit de la cuisinière			
Configuration de pressiom	10" de colonne d'eau			
Allumage Du Brûleur	H. T. Étincelle			
Fours Électriques	240 V 60 Hz Phase Simple 30 A			
Four Du Haut Puissance	3.0 kW			
Four Du Bas Puissance	0.9 kW			

Vue En Coupe Type des Flamme de Brûleur

Gauche-Avant Brûleur de Plaque de Cuisson

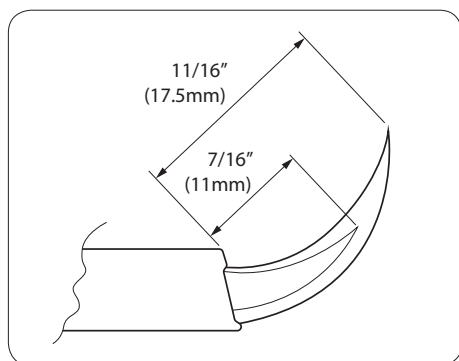

Droit Arrière Brûleur de Plaque de Cuisson

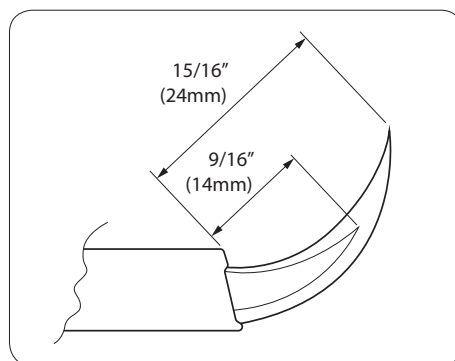

Gauche Arrière et Droit Avant Brûleur de Plaque de Cuisson

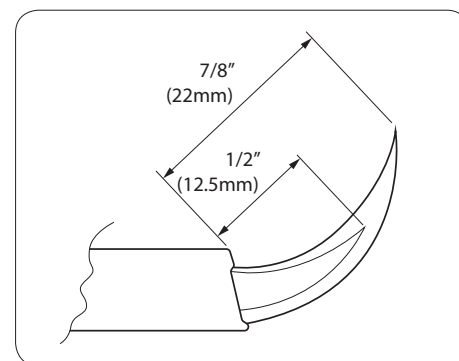

AGA City60 Gas Hob (AUS)

WARNING SERVICING TO BE CARRIED OUT ONLY BY AN AUTHORISED PERSON.

Disconnect from electricity and gas before servicing. Check appliance is safe when you have finished.

Check the 'Technical Data' section, that the hob is convertible to the gas you want to use.

A suitably competent person must perform the conversion. After conversion the installation must comply with the relevant regulations and also the local electricity supply company requirements. Read the instructions before converting this appliance.

- ⚠ Failure to convert the appliance correctly could invalidate any warranty or liability claims and lead to prosecution.**
- ⚠ When servicing or replacing gas carrying components disconnect from the gas supply before starting operation. Check the appliance is gas sound after completion.**
- ⚠ DO NOT use reconditioned or unauthorised gas controls.**
- ⚠ Disconnect from the electricity and gas supply before servicing.**
- ⚠ Before electrical reconnection, check that the appliance is electrically safe.**

Injectors

Remove the burner caps and flame spreaders. Remove the old jets. Fit the new jets (see 'Technical Data' section for the correct jets). Reassemble in the reverse order. (See **Fig. 1.13**, **Fig. 1.14** and **Fig. 1.15**).

Bypass Screw Adjustment

Pull off all the control knobs and bezels. Turn the bypass screw on each control clockwise to the stop (See **Fig. 1.16**).

Gas Regulator applies to City60 Australia

The gas regulator, located on the right hand side of the cooker (see **Fig. 1.17**), is pre-set for Nat. Gas. Remove the cap from the regulator, pull the plastic insert from the cap, turn and re-locate it into the cap as shown (see **Fig. 1.18**). Replace the cap.

Stick on Label

Stick the LP gas label over the natural gas part of the appliance data label.

Pressure Testing

Connect the appliance to the gas supply.

The pressure test point is situated just below hotplate level on the rear right hand side of the cooker.

Place the wok burner head, burner cap and ring into position on the hotplate. Light the burner by pushing in the appropriate control knob and turning it anticlockwise to the FULL ON position (large flame symbol).

For **Natural Gas** appliances, the manifold pressure should be 4 inches water gauge (1 kpa).

For **LPG** appliances, the manifold pressure should be 10 inches water gauge (2.54kpa).

Turn off the tap, disconnect the pressure gauge and refit test point blanking screw.

Check operation of all the burners.

Check for gas tightness.

Assembly of burners and adjustment

FITTING BURNER CAP - RAPID AND SEMI-RAPID BURNERS

PLACE BURNER CAP OVER RETAINING LUGS, THEN TURN CAP CLOCKWISE TO LOCK INTO POSITION.

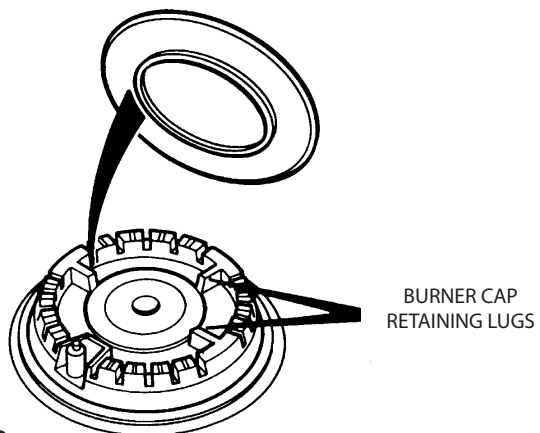

Fig. 1.13

DESN 511617

ASSEMBLY OF RAPID AND SEMI-RAPID BURNERS

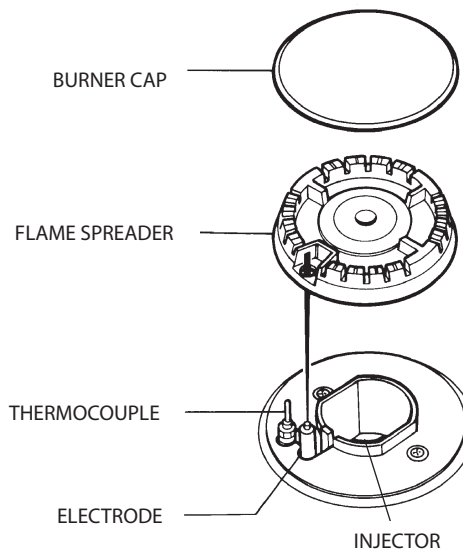

Fig. 1.14

DESN 513513

WOK BURNER

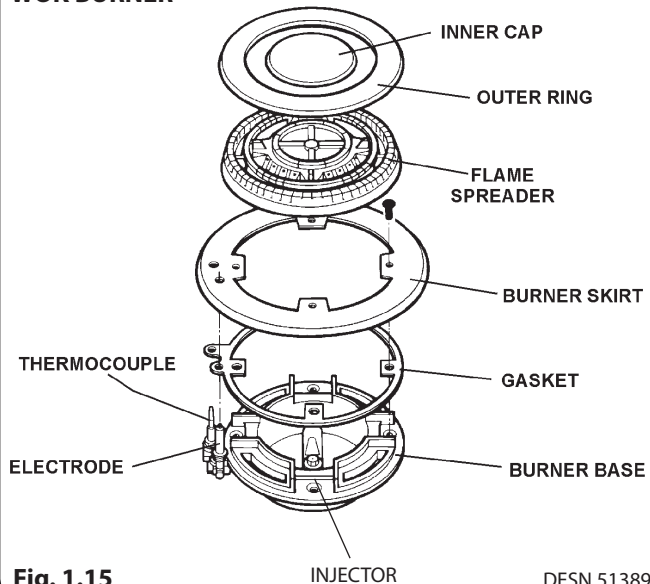

Fig. 1.15

DESN 513898

BYPASS SCREW

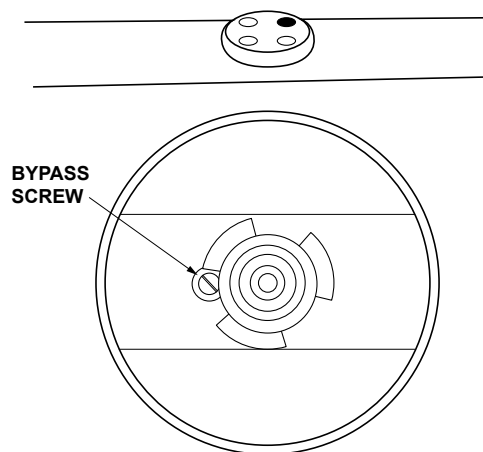

Fig. 1.16

GAS REGULATOR

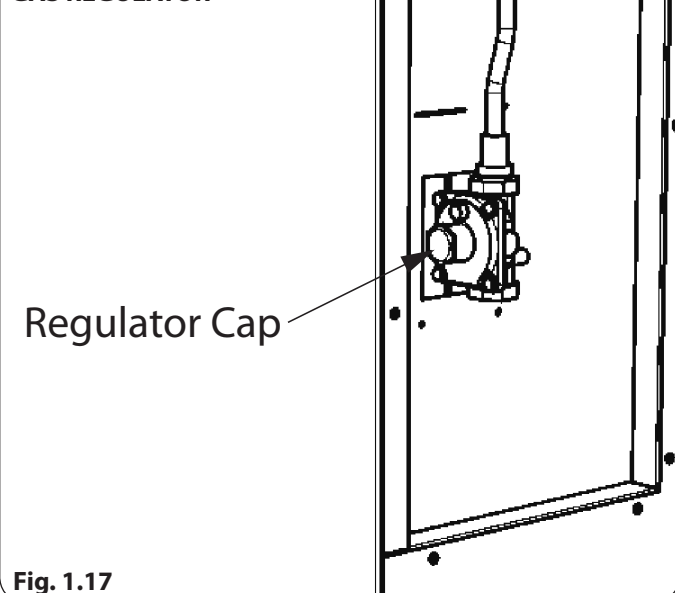

Fig. 1.17

REGULATOR CAP

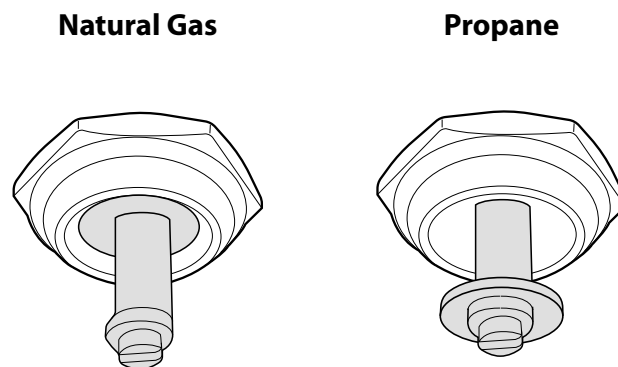

Fig. 1.18

Technical data

This appliance is supplied set for Natural Gas (NG) at a pressure of 1 kPa (4" wg). It must be converted to run on Propane X, at a pressure of 2.54 kPa (10" wg).

NATURAL GAS	Left-hand Front	Right-hand Rear	Left-hand Rear	Right-hand Front
BURNER TYPE	ULTRA-RAPID WOK	RAPID	SEMI-RAPID	SEMI-RAPID
MAXIMUM HEAT INPUT	3.9 KW	3.5 KW	1.95 KW	1.95 KW
	14.0 MJ/hr	12.5 MJ/hr	7.0 MJ/hr	7.0 MJ/hr
INJECTOR MARKING	170	155	118	118

PRESSURE POINT POSITION:	Just below hotplate level on rear right-hand side of the appliance.
PRESSURE SETTING:	1 kPa (4" wg)
BURNER IGNITION:	H.T. Spark

PROPANE X	Left-hand Front	Right-hand Rear	Left-hand Rear	Right-hand Front
BURNER TYPE	ULTRA-RAPID WOK	RAPID	SEMI-RAPID	SEMI-RAPID
MAXIMUM HEAT INPUT	14.0 MJ/hr 3.9 KW (278 g/h) (0.55 l/h)	11.5 MJ/hr 3.2 KW (227 g/h) (0.45 l/h)	6.8 MJ/hr 1.9 KW (134 g/h) (0.28 l/h)	6.8 MJ/hr 1.9 KW (134 g/h) (0.28 l/h)
	INJECTOR SIZE (mm)	1.05	0.94	0.72

PRESSURE POINT POSITION:	Just below hotplate level on rear right-hand side of the appliance.
PRESSURE SETTING:	2.54 kPa (10" wg)
BURNER IGNITION:	H.T. Spark
ELECTRIC GRILL AND OVENS:	240 VOLT, 50 Hz, SINGLE PHASE 30 AMP
TOP OVEN POWER RATING	3.0 kw (230V) / 3.2 kw (240V)
LOWER OVEN	0.9 kw (230V) / 1.0 kw (240V)

The data plate is located on a pull out plate, behind the plinth cover.

Weight of appliance: 215 kg (474 lbs)

Gas hob overview Fig. 1.19

- A. Oven knob
- B. Wok burner and knob
- C. Rear semi-rapid burner and knob
- D. Rear rapid burner and knob
- E. Front semi-rapid burner and knob

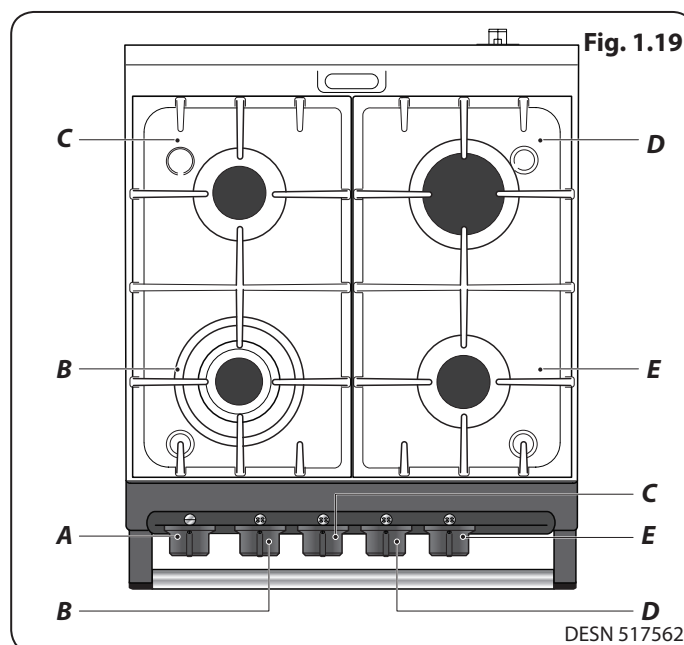

Typical section view of burner flames

L.H.F. Hotplate Burner

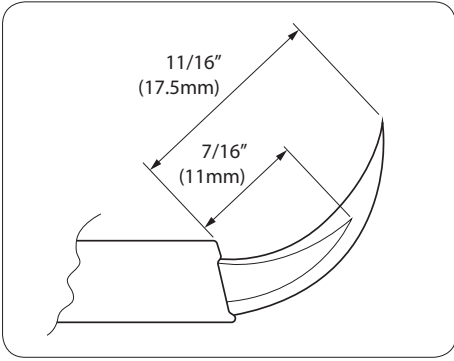

R.H.R. Hotplate Burner

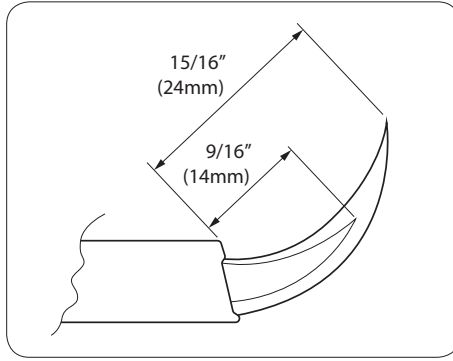

L.H.R. and R.H.F. Hotplate Burner

