



**Rayburn Heatranger®  
60K, 80K, 100K**

**User Guide &  
Installation Instructions**

**CAUTION: THIS UNIT IS HEAVY, PROPER EQUIPMENT AND ADEQUATE MANPOWER MUST BE USED IN MOVING THE RANGE TO AVOID DAMAGE TO THE UNIT OR THE FLOOR.**

**REMEMBER**, when replacing a part on this appliance, use only spare parts that you can be assured conform to the safety and performance specification that we require.

**DO NOT** use reconditioned or copy parts that have not been clearly authorised by Rayburn.

**PLEASE READ THESE INSTRUCTIONS BEFORE USING THIS APPLIANCE  
AND KEEP IN A SAFE PLACE FOR FUTURE REFERENCE.**

## Useful Information

It maybe useful to make a note of your Rayburn appliance Serial Number when it is being installed.

The serial number can be found on the rear of the appliance.

## My Rayburn Details:

**Serial No:**

**Rayburn Service No:**

---

**Dealer or store contact  
No:**

---

**Date of Installation:**

---

---

# Contents

<b>1. Health and Safety</b>	<b>1</b>
<b>2. Introduction</b>	<b>3</b>
<b>3. Rayburn Heatranger® Overview</b>	<b>4</b>
GENERAL NOTE ON SETTING THE PROGRAMMER	4
<b>4. Operating the Rayburn Heatranger®</b>	<b>5</b>
GENERAL NOTE ON SETTING THE PROGRAMMER	5
SETTING THE CORRECT TIME AND DAY	5
OPERATING THE OVEN MANUALLY	5
SETTING THE COOKING PROGRAMME	5
PROGRAMMING CENTRAL HEATING, HOT WATER OR OVEN PREHEAT	6
SETTING THE ALARM TIMER	7
BOOST FUNCTION	7
ADVANCE FUNCTION (IN AUTO MODE ONLY)	7
DISPLAY LOCK FUNCTION	7
POWER FAILURE	8
HOTPLATE / COOKING MODE	8
HOTPLATE INSULATING COVERS	8
COOKING UTENSILS	9
CLEANING	9
CHIMNEY CLEANING	9
MILD STEEL	9
OVENS	9
HOTPLATE	9
GENERAL INFORMATION	10
THE CARE OF YOUR COOKER	10
COOKWARE	11
USER COOKING TIPS	13
FAULT FINDINGS	14
<b>5. Installation Introduction</b>	<b>15</b>
<b>6. Product Dimensions Rayburn Heatranger®</b>	<b>16</b>
<b>7. Technical Data</b>	<b>17</b>

<b>8. Installation Process</b>	<b>20</b>
LOCATION	20
HEARTH CONSTRUCTION	20
ELECTRICAL SUPPLY	20
TO ACCESS THE CONTROL PANEL	20
PRE-INSTALLATION CHECK	21
CHIMNEY	21
SEALING	21
FLUE HEIGHT	23
FLUE SYSTEM	23
DRAUGHT REQUIREMENTS	23
FLUE LINERS	23
FACTORY MADE INSULATED CHIMNEYS	24
VENTILATION & COMBUSTION AIR REQUIREMENTS	24
OUTSIDE AIR CONNECTION	24
HEATING PIPE FITTINGS	24
DOWN DRAUGHTS	25
WATER PIPE SIZE	25
DRAINING	26
INTERNAL PUMP THERMOSTAT	26
WATER CIRCUIT TEMPERATURE	26
CARE FOR YOUR CENTRAL HEATING SYSTEM	26
INDIRECT DOMESTIC CYLINDER	26
SERVICING	27
GENERAL MAINTENANCE	27
SAFETY VALVE	27
4 ZONE HEATING SYSTEM	33
<b>9. Fuel Installation</b>	<b>35</b>
OIL STORAGE TANKS	35
FUELS	35
FUEL SUPPLY LINE	35
SINGLE PIPE SUPPLY SYSTEM: BOTTOM OF OIL STORAGE TANK ABOVE BURNER	35
TWO PIPE SUPPLY SYSTEM: BOTTOM OF OIL STORAGE TANK BELOW OR LEVEL WITH BURNER	35
SINGLE PIPE SYSTEM: WITH DE-AERATION DEVICE BOTTOM OF OIL STORAGE TANK BELOW OR LEVEL WITH BURNER	35
TIGER LOOP OIL SUPPLY	36
INSTALLATION CHECK LIST	36
REMOVAL OF TRANSPORT SCREW/S FUNCTION	37
<b>10. Installation Checklist</b>	<b>39</b>

# 1. Health and Safety

---

## Consumer Protection

As a responsible manufacturer, we take care to make sure that our products are designed and constructed to meet the required safety standards when properly installed and used. It is essential that the base or hearth on which the cooker sits should be level and capable of supporting the total weight of one or both units.

The front plinth cover is removable and must not be obstructed by flooring or tiles. If necessary the cooker must be raised by the thickness of the tiles to ensure the plinth can be removed.

- ⚠ Children less than 8 years of age shall be kept away unless continuously supervised. Cleaning and user maintenance MUST not be made by children without supervision.**
- ⚠ CHILDREN SHOULD BE KEPT AWAY FROM THE APPLIANCE AS SOME SURFACES CAN BECOME HOT TO THE TOUCH.**
- ⚠ WARNING: ACCESSIBLE PARTS MAY BECOME HOT DURING USE. TO AVOID BURNS AND SCALDS CHILDREN SHOULD BE KEPT AWAY.**
- ⚠ WARNING: During use the appliance becomes hot. Care should be taken to avoid touching heating elements inside the ovens.**
- ⚠ WARNING : Any spillages should be removed from the hotplate lids before they are opened.**
- ⚠ WARNING : This appliance is not intended to be operated by means of an external timer not approved by Rayburn or a separate remote-control system.**
- ⚠ CAUTION: The cooking process has to be supervised. A short term cooking process has to be supervised continuously.**
- ⚠ WARNING: Danger of fire: Do not store items on the cooking surfaces.**
- ⚠ WARNING: Unattended cooking on a hob with fat or oil can be dangerous and may result in fire. NEVER try to extinguish a fire with water, but switch off the appliance and then cover flame e.g. with a lid or fire blanket.**
- ⚠ IMPORTANT: Oil is a fire risk, NEVER leave pans containing oil or fat unattended during the heating or cooking period.**
- ⚠ Never fill the pan more than one-third fill of fat or oil.**
- ⚠ Installation and maintenance must be performed by a qualified installer or service agency.**

- ⚠ WARNING! This appliance must be installed with an appropriate device that will allow permanent disconnection of the Live and Neutral conductors. During Installation or disconnection prior to any electrical work, the appliance must be permanently disconnected from the Supply (Live) and Neutral Conductors.**
- ⚠ If a supply cord is damaged it must be replaced by the manufacturer, its service agent or similarly qualified persons in order to avoid a hazard.**
- ⚠ DO NOT use a steam cleaner on your cooker.**
- ⚠ To avoid overheating, DO NOT install the cooker behind a decorative door.**
- ⚠ For correct installation of the oven shelves, refer to the user instructions.**
- ⚠ DO NOT use abrasive pads, caustic cleaners, oven cleaners or metal scrapers to clean the surfaces of the enamel.**
- ⚠ IMPORTANT: Rayburn recommends Vitreous Enamel Association approved cleaners for cleaning the vitreous enamelled surfaces of this product.**
- ⚠ DO NOT put oven doors or resting plates in a dishwasher.**
- ⚠ Children should be supervised to ensure that they do not play with the appliance.**

The appliance can be used by children aged from 8 years and above and persons with reduced physical, sensory or mental capabilities or lack of experience and knowledge if they have been given supervision or instruction concerning use of the appliance in a safe way and understand the hazards involved.

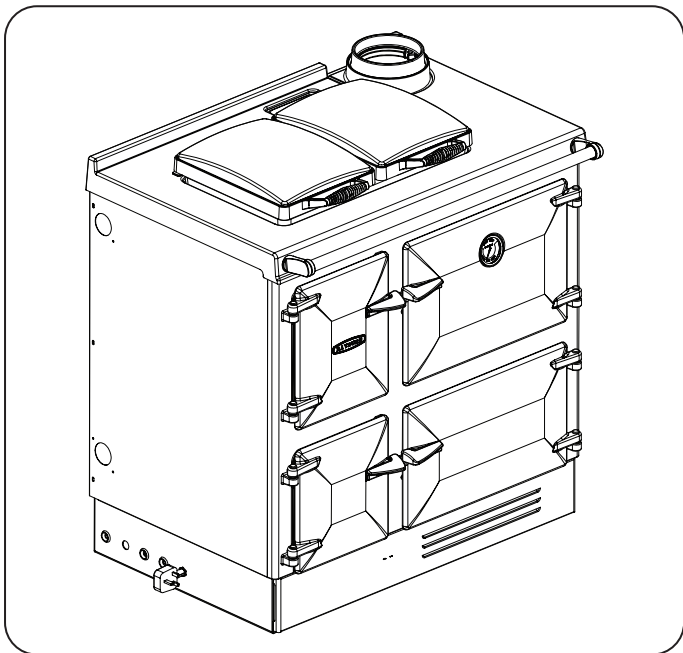
The appliance may contain some of the materials that are indicated below. It is the Users/Installers responsibility to ensure that the necessary personal protective clothing is worn when handling where applicable, the pertinent parts that contain any of the listed materials that could be interpreted as being injurious to health and safety, see below for information.

### Glues and Sealants

Exercise caution - if they are still in liquid form use face mask and disposable gloves.

### Glass Yarn, Mineral Wool, Insulation Pads, Ceramic Fibre

May be harmful if inhaled. May be irritating to skin, eyes, nose and throat. When handling avoid contact with skin or eyes. Use disposable gloves, face-masks and eye protection. After handling wash hands and other exposed parts. When disposing of the product, reduce dust with water spray, ensure that parts are securely wrapped.



### General

- In the event of a fire, cover the pan with a lid and switch OFF the electricity.
- Smother the flames on the hob rather than attempting to remove the pan to the outside.
- Burns and injuries are caused almost invariably by picking up the burning pan to carry outside.

### Deep Fat Frying

- Use a deep pan, large enough to completely cover the appropriate heating area.

**DO NOT** hang dish towels on the handrail. Doing so will restrict the flow of air through the induction air outlet which could affect performance.

When the oven (s) are on **DO NOT** leave any oven door open for long periods, this will affect the temperature of the oven and may allow controls to become hot.

## 2. Introduction

---

To help you make the best use of your cooker, **PLEASE READ THIS BOOKLET CAREFULLY.**

To ensure safety, satisfaction and reliable operation, this quality cooker should be installed and commissioned by a trained and competent person. The provision of the central heating facility and hot water systems involved, must conform to good plumbing practice, current standards and OFTEC regulations.

As manufacturers and suppliers of cooking and heating appliances, we take every possible care to ensure as reasonably practicable, that these appliances are so designed and constructed as to meet the general safety requirements when properly used and installed.

Section 10 of the Consumer Protection Act 1987.

Safety, Health and Welfare at Work Act.

**The complete installation must be done in accordance with current Standards and Local Codes. It should be noted that the requirements and these publications may be superseded during the life of this manual. Your new cooker is guaranteed, the guarantee is only applicable if the cooker has been installed in accordance with the Installation Instructions.**

The cooker is designed specifically for domestic use and responsibility will not be accepted for use in any other installation. When the Cooker is first used, a slight odour may be noticed - this should cease after a short period of use.

**The Installation must comply with the following:**

- B.S. 5410: Oil Installations Part 1 under 45kW.
- The Building Regulations: Part J England & Wales Part F Section 4 Scotland.
- Part L Northern Ireland.
- The Control of Pollution (Oil) Regulations.
- B.S. 5449: Forced circulation hot water, central heating systems for domestic installations.
- Health and Safety at Work Act.
- B.S. 7671: Requirements for Electrical Regulations.
- Safety Document 635: The Electricity at Work Regulations.
- B.S. 7593: Treatment of Water in Domestic Hot Water Systems.
- B.S. 7074: Part 1 & 2: Hot Water Supply.
- B.S. 4814: Sealed System.

**Important: Control of Substances Harmful to Health -**

It is the Users/Installers responsibility to ensure that the necessary personal clothing is worn when handling materials that could be interpreted as being injurious to health and safety.

When handling Firebricks, Fire Cement or Fuels, use disposable gloves.

Exercise caution and use disposable masks and gloves when handling glues and sealants.

When working with fibre glass, mineral wool, insulation materials, ceramic blanket/board, avoid inhalation as it may be harmful if inhaled. Avoid contact with skin, eyes, nose and throat, use disposable protection.

Installation should be carried out in a well ventilated area.

This combined appliance is capable of providing 29.3 kW (100,000 Btu's/hr) or 23.45 kW (80,000 Btu's/hr) or 17.58 kW (60,000 Btu's/hr) to water, 2.96kW (10,113 Btu's/hr) for hotplate, space heating and ovens.

When the appliance is set to cooking mode it will also provide hot water to the domestic system and space heating.

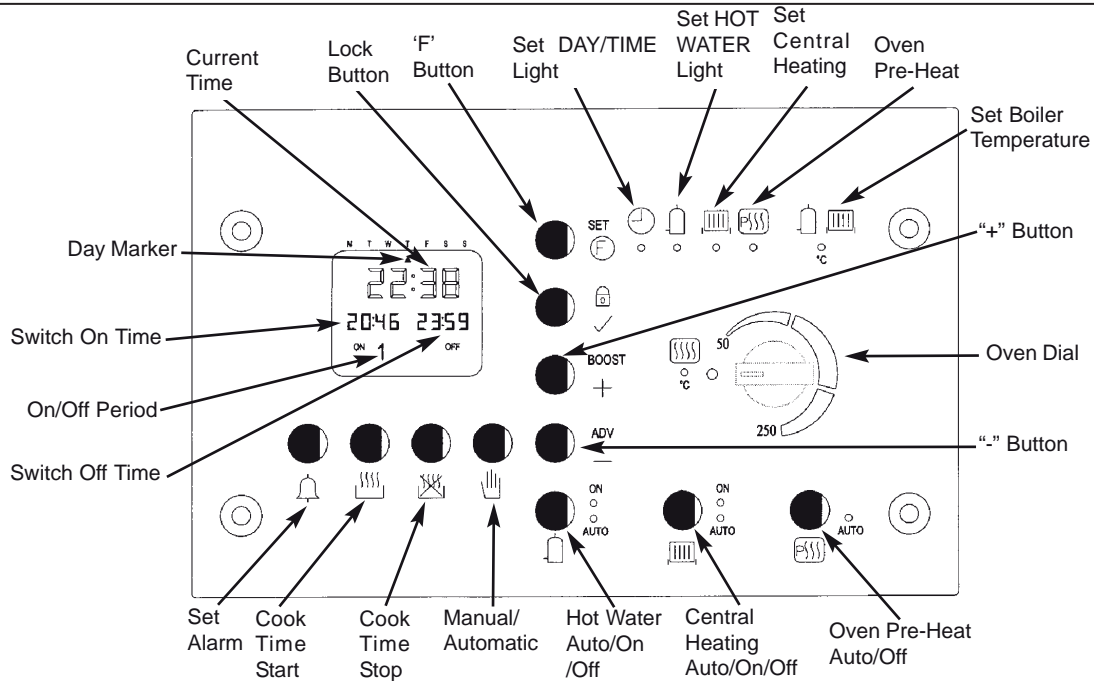
Heat transfer to the domestic system when oven is set to 230°C (446°F)

Mean Output: 4,820 Btu's/hr 11.41 kW/hr

**This appliance is hot while in operation and retains its heat for a long period of time after use. Children, aged or infirm persons should be supervised at all times and should not be allowed to touch the hot working surfaces while in use or until the appliance has thoroughly cooled.**

### 3. Rayburn Heatranger® Overview

Fig. 3.1



The programmable clock controls your central heating system and oven preheat function, and allows you to set your cooking times automatically. The clock offers the following features:

- 7-Day heating programme.
- Three ON/OFF switching times each day.
- Facility allowing a separate heating programme for Weekdays (MON-FRI) and a different programme for the Weekend (SAT- SUN).
- Separate programme facilities for Central Heating, Hot Water and Oven preheat needs.
- Independent oven timer.
- Advance buttons for Central Heating, PreHeat and Hot Water functions.
- Boost Facility for Central Heating and Hot Water functions.
- Alarm Timer allowing timing of cooking.
- Built-in battery to prevent loss of programmes during power cuts.
- Diagnostics.

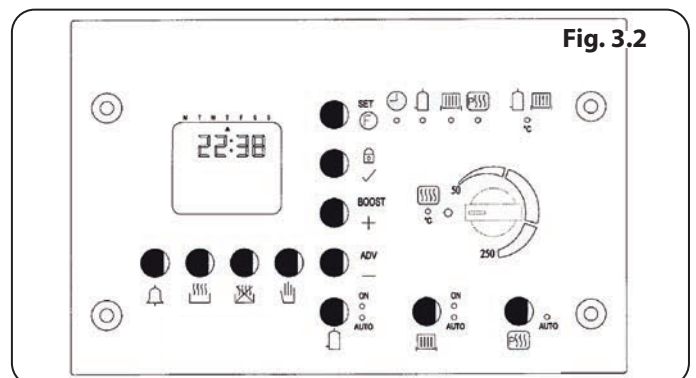
#### GENERAL NOTE ON SETTING THE PROGRAMMER

When there is a time or setting that can be edited, or adjusted by the user, then that time flashes to indicate that it is editable. Editing is carried out by scrolling the + or - buttons. These buttons have a different function when there are no editable times.

#### SETTING THE CORRECT TIME AND DAY (See Fig.2)

1. Press the “F” button and hold it for five seconds. The red “SET DAY/TIME” light will illuminate and the arrow signifying the day setting will flash.
2. Adjust the day setting by pressing the + or - buttons, until the day marker is pointing to the correct day.
3. Press the “✓” button to accept the setting, then the hour figure will flash. Adjust the hour setting by pressing the + or - buttons.
4. Press the “✓” button and the minutes figure will flash. Adjust the minute setting by pressing the + or - buttons.
5. Press the “F” button five times to exit the setting time facility.(or simply do nothing – the setting mode will revert to the normal mode after 60 seconds.

Fig. 3.2





## 4. Operating the Rayburn Heatranger®

### GENERAL NOTE ON SETTING THE PROGRAMMER

When there is a time or setting that can be edited, or adjusted by the user, then that time flashes to indicate that it is editable. Editing is carried out by scrolling the + or - buttons. These buttons have a different function when there are no editable times.

### SETTING THE CORRECT TIME AND DAY (Fig. 4.1)

1. Press the "F" button and hold it for five seconds. The red "SET DAY/TIME" light will illuminate and the arrow signifying the day setting will flash.
2. Adjust the day setting by pressing the + or - buttons, until the day marker is pointing to the correct day.
3. Press the "✓" button to accept the setting, then the hour figure will flash. Adjust the hour setting by pressing the + or - buttons.
4. Press the "✓" button and the minutes figure will flash. Adjust the minute setting by pressing the + or - buttons.
5. Press the "F" button five times to exit the setting time facility. (or simply do nothing – the setting mode will revert to the normal mode after 60 seconds).

### OPERATING THE OVEN MANUALLY

1. Simply turn the oven temperature control until the temperature desired appears on the LCD screen. (If oven ON and OFF times are shown, cancel the oven timer by pressing the Oven Manual button)
2. When cooking is finished, to turn the oven OFF, rotate the temperature control fully anticlockwise
3. Tip: If you use the oven pre-heat, the oven will attain the set temperature much more quickly! Simply program pre-heat to come on about half an hour before you normally would start cooking.

### SETTING THE COOKING PROGRAMME

1. Press the "[🔔]" button and the "SWITCH ON" and "SWITCH OFF" times will appear below the current time display. (Fig. 4.2)
2. To set the cook start time, press the "[🕒]" button and the "COOK START" time will flash.
3. Adjust it to the desired start time using the + or - buttons.
4. To set cook stop time, press the "[🕒]" button and the "COOK STOP" time will flash.
5. Adjust it to the desired finish time using the + or - buttons.
6. Set the oven thermostat to the required temperature.
7. To return to Manual oven cooking, press the "[🔔]" button.

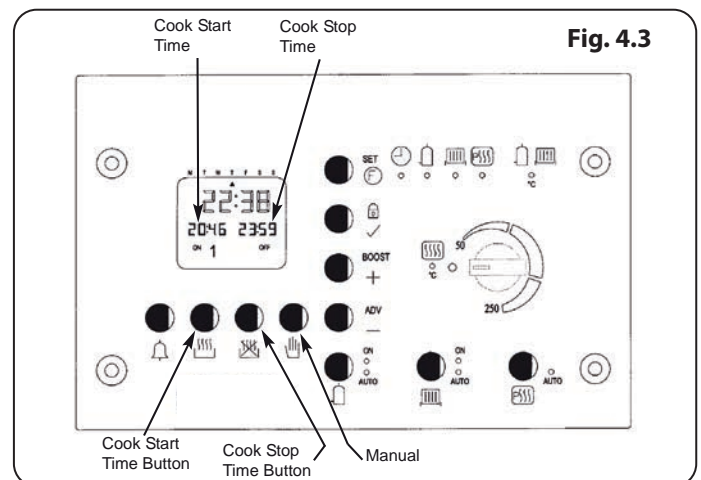
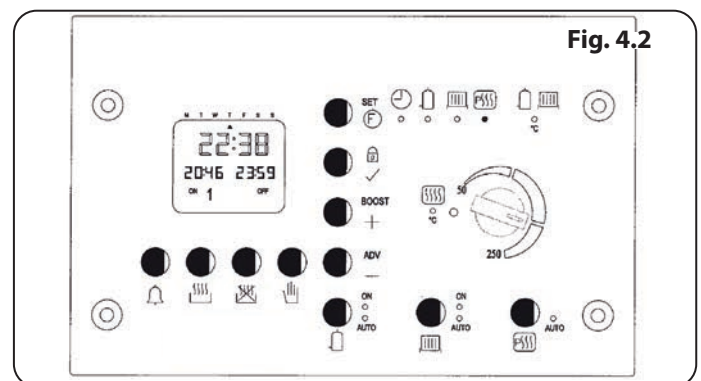
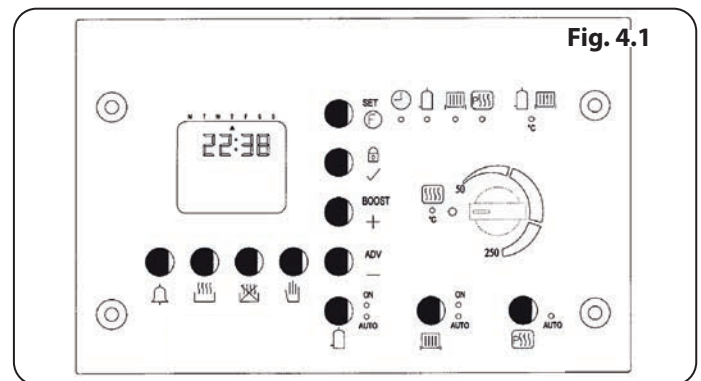


Fig. 4.4

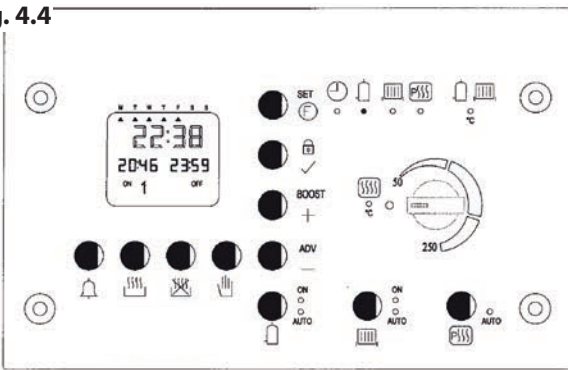


Fig. 4.5

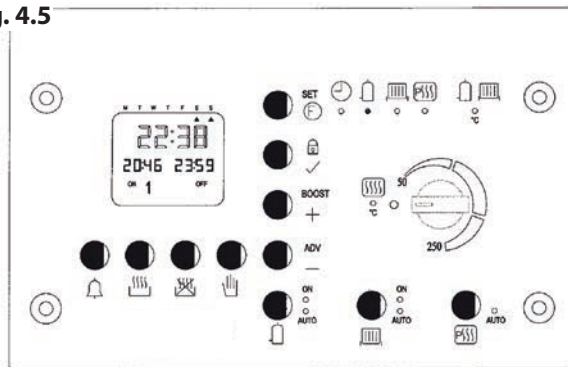
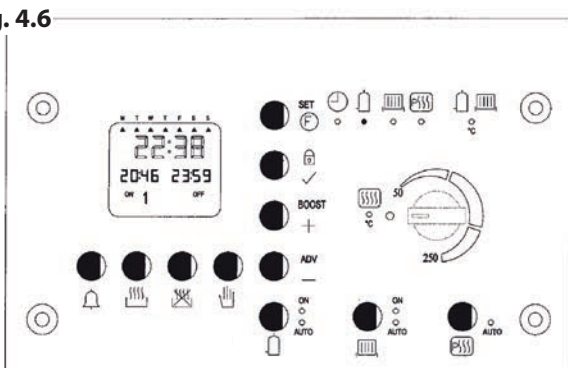


Fig. 4.6



8. If desired, you can leave the oven timer selected, in which case the oven will come on to the selected temperature at the same time every day.

**PROGRAMMING CENTRAL HEATING, HOT WATER OR OVEN PREHEAT**

The heating can be set individually for both Central Heating, Hot Water, and Oven preheat and each setting has 3 on/off programmes for each day. These can be set in three different ways:

- A. All 7 Days simultaneously.
  - B. First Monday-Friday, then Saturday & Sunday
  - C. Each Day Individually.
1. Press the "F" button and hold it for five seconds until the red "SET DAY/TIME" light illuminates. Press the "F" button again and the red light moves to set Domestic Hot Water. Each subsequent time it is pressed the mode will move on to the next position.
  2. The display will be as shown in Fig. 4.3, with the arrow flashing underneath the day you wish to program for. The time on the bottom left and bottom right sides are the ON and OFF times respectively. The number "1" at the bottom of the display signifies that these are the times for the first ON/OFF setting of the day/days.
  3. The programs can be set for the individual days, for weekdays, for weekends and for the entire week. The days you wish to program for can be changed by moving the flashing arrow using the + and - buttons. Fig. 4.4 shows the day setting for setting the same programme for Monday to Friday, Fig. 4.5 shows it for setting the same programme for Saturday & Sunday and Fig. 4.6 shows it for setting the same programme for the entire week.
  4. After selecting the day, press the "✓" button and the 1st ON time will flash. This time can be adjusted in ten minute intervals using the + and - buttons.
  5. Press the "✓" button and the corresponding OFF time can be adjusted using the + and - buttons. Note that you cannot set an OFF time to be earlier than ON time, or the ON time to be earlier than the previous OFF time. The programmer will automatically correct settings if you do this.
  6. The 2nd & 3rd ON/OFF times can be viewed by pressing the "✓" button and can be set by repeating Steps 4 & 5.
  7. Note that if you do not want to use all three ON/OFF times, simply set the OFF time the same as the ON time.
  8. To exit DHW setting press the "F" button four times, or press once to edit the Central heating programs. Press once more to edit the pre-heat programs in just the same way.
  9. To have the appliance operate on the programmed settings, press the appropriate button on the right hand side of the control panel once so that a light can be seen beside auto.

### SETTING THE ALARM TIMER

The alarm timer allows cooking to be timed up to a period of 99 minutes. (it does not turn the oven on or off) The alarm can be set by following the procedure below:

1. Press the "alarm" button and a "00 ALARM" will flash on the display (**Fig. 4.7**).
2. Adjust the alarm time to the desired setting using the + or - buttons.
3. The timer will start immediately when the setting + or - button is released.
4. When the time has elapsed, the acoustic signal will sound for 60 seconds and the word Alarm flashes. It can be cancelled by pressing the Alarm button. Note: This timer operates only when the oven is set to "manual" mode.

### BOOST FUNCTION

By pressing the "BOOST" button, boost will be displayed and the symbols for central heating and hot water will flash. Then pressing either the "Hot Water", "Central Heating" or "Pre Heat" buttons will turn this mode on for 1 hour. The symbols will flash for 10 seconds and if neither of the 3 options are selected then the display will revert to current time and day. If a mode is selected the symbol for this mode and the word "BOOST" will remain displayed for 1 hour, providing none of the oven control functions on the clock are used within this hour. Boost can be cancelled by pressing the relevant function button **Fig. 4.8**.

### ADVANCE FUNCTION (IN AUTO MODE ONLY)

By pressing the "ADV" button, ADVANCE will be displayed and the symbols for central heating and hot water will flash. Then pressing either the "Hot Water" or "Central Heating" or "Pre-heat" buttons will bring forward the next switching time for that mode. The symbols will flash for 10 seconds within which one of the 3 options must be selected before the display will revert to current time and day.

Advance can be cancelled by pressing the relevant function button **Fig. 4.8**.

**Note:** Advance function is only applicable when timer is in 'Auto Mode'.

The DHW, Heating and oven Pre-heat programs can be turned OFF by de-selecting AUTO, so that no lights are visible.

The DHW and Heating can also be set to continuous ON by pressing the button so that the ON light illuminates.

### DISPLAY LOCK FUNCTION

By pressing and holding the "LOCK" Button for 10 seconds the display will become locked, and LOCKED will be displayed. To unlock the display press and hold the "LOCK" button for 10 seconds. If any button is pressed while the display is locked the word "LOCKED" will flash on the display.

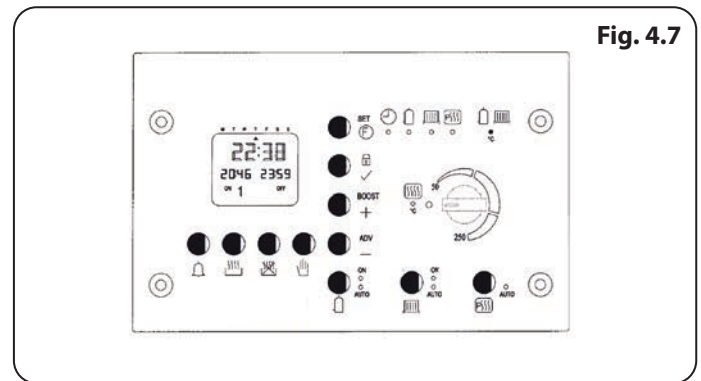


Fig. 4.7

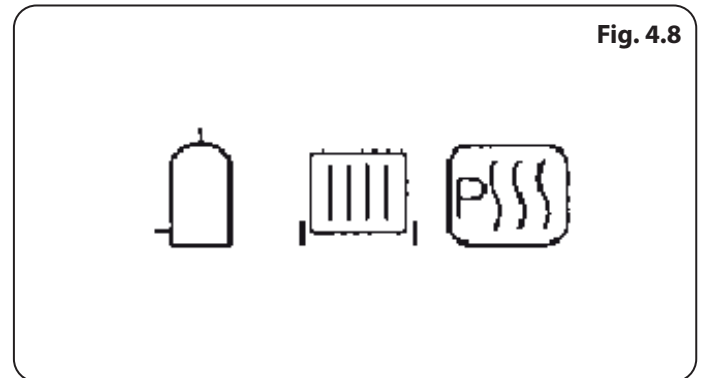
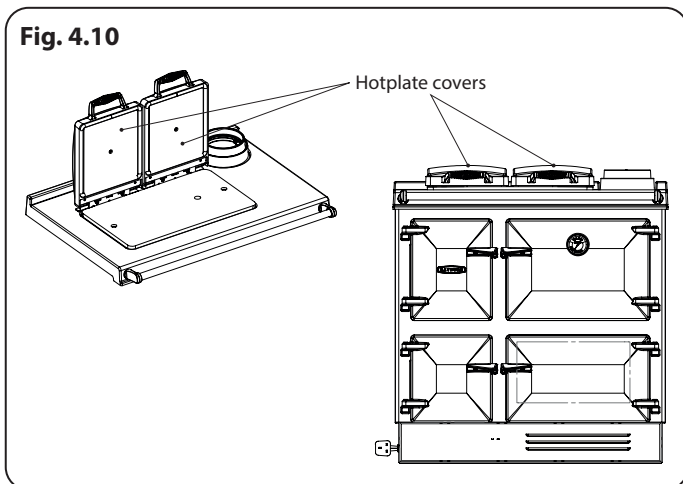
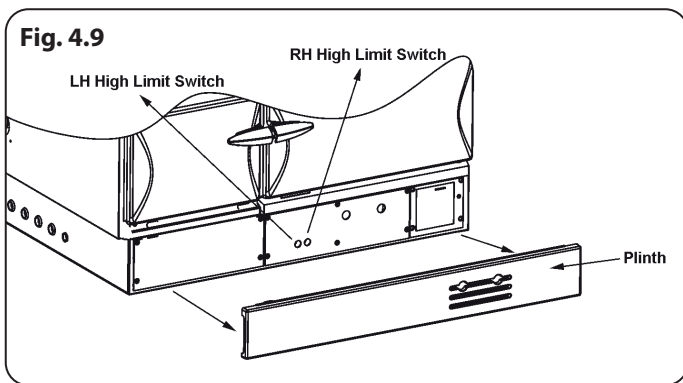


Fig. 4.8



## POWER FAILURE

Your clock has a built-in battery to ensure correct operation after a mains supply power cut. No action should be necessary following a power loss.

## Diagnostics

If an error occurs in the appliance the electronics will detect it and narrow down the problem area.

Code no 1.	Oven thermocouple failure
Code no 2	Boiler thermistor failure
Code no 3	Flue thermistor failure (Gas only)
Code no 4	Boiler high limit switch opened
Code no 5	Oven high limit switch opened
Code no 6	Flue thermistor over temperature (Gas only)
Code no 8	Oven burner faulty
Code no 9	Boiler Excess Temperature

When an error occurs it can be reset by pressing the "✓" button for 5 seconds, the code no. on the display will disappear, if the error is still present the code no. will reappear, it will be necessary to call the service centre.

In the special case of a no. 9 code this could be due to all radiator valves being turned off. It is a requirement that at least 1 radiator in zone 1 is permanently on.

If Code 4 or 5 appear on the display screen prior to the fault being cleared using the F button, it will require the high limit switches to be reset, to access and reset the high limit switches take the following steps:

1. Remove plinth at base of cooker, the high limit switches are located in the centre of the base plate, **Fig. 4.9**.
2. Press the LH & RH buttons to reset the High Limit reset switches, then press the F button for 5 seconds to clear the fault on the display screen.

However, if the high limit does not reset it may be due to the appliance being excessively hot, wait until the appliance has cooled and press the high limit switches again, if they do not reset when appliance is cool, please contact your local service engineer.

## HOTPLATE / COOKING MODE

The hot plate is machined ground for maximum heating and it is temperature graded, the left hand side over the burner being the hottest and the right hand side is suitable for simmering.

## HOTPLATE INSULATING COVERS (Fig. 4.10)

The insulating covers retain most of the heat that would otherwise be radiated into the kitchen. They also retain the heat in the hot plates so that rapid heating of cooking utensils will occur when one or both of them are lifted for cooking purposes.

**▲ IMPORTANT: WHEN HOTPLATE IS NOT IN USE ENSURE THAT HOTPLATE COVERS ARE IN A DOWN POSITION.**

## COOKING UTENSILS

For best cooking results and economy of operation use heavy based, flat bottomed utensils.

**⚠ IMPORTANT: WE DO NOT RECOMMEND DEEP FAT FRYING ON THIS APPLIANCE.**

**⚠ IMPORTANT: DO NOT USE MIS-SHAPED PANS WHICH MAY BE UNSUITABLE DO NOT USE ROUND BASED WOKS.**

## CLEANING

**⚠ IMPORTANT: BE CAREFUL OF THE HOT APPLIANCE.**

General cleaning must be carried out when the cooker is cool.

Rayburn cookers are finished in a high gloss vitreous enamel. To keep the enamel in the best condition observe the following tips:

1. Wipe over daily with a soapy damp cloth, followed by a polish with a clean dry duster.
2. If milk, fruit juice or anything containing acid is spilt on the hob or down the cooker, be sure to wipe it immediately or the vitreous enamel may be permanently discoloured.
3. Keep a damp cloth handy while cooking, to wipe up any spills as they occur, so they do not harden and become more difficult to remove later.
4. If spills do become baked on, a cream cleanser can be used. For stubborn deposits a soap impregnated pad can be carefully used on the vitreous enamel.
5. Use only products recommended by the Vitreous Enamel Association, these products carry the Vitramel label.
6. In the oven, spills and fat splashes are carbonised at high temperatures: occasionally brush out with a stiff brush. The shelves can be soaked and cleaned with a cream cleanser.
7. Both insulating covers should be raised and allowed to cool before cleaning the enamel with a soapy damp cloth. Use a wire brush to keep the cast iron hotplate clean.

**DO NOT USE ABRASIVE PADS OR OVEN CLEANERS CONTAINING CITRIC ACID ON ENAMELLED SURFACES. ENSURE THAT THE CLEANSER MANUFACTURERS INSTRUCTIONS ARE ADHERED TO.**

## CHIMNEY CLEANING

Whichever type of flue is chosen, there must be cleaning access to the whole of the flue system. The flue of the chimney will need to be cleaned regularly. The combustion products of any burning appliance will have a descaling effect on hardened soot deposits left from burning solid fuels.

Although, the chimney may have been cleaned of loose soot prior to installation, it is imperative that the chimney is inspected for scaled soot particles after the first month of operation and any loose material removed to avoid blockage.

The frequency of cleaning will depend a lot on how your cooker is run, but to start with, make a point of inspecting the flue system every six months. This period may well be extended to twelve months as time goes by if there is little sign of deposits.

## MILD STEEL

The steel panels and splash back (if fitted) must not be cleaned with steel wool. Use only washing up liquid in hot water with a lint free cloth. Dry off and apply a coat of good quality furniture polish.

## OVENS

Grease spillages will burn off from the oven interior, when the oven is hot and any other loose materials can be wiped out with a cloth, when cold. Stubborn stains in the area and on the shelves in the oven can be cleaned off with a paste of bread soda and water

## HOTPLATE

The hotplate may be cleaned by using a fine steel wool pad to remove rust or cooking stains. Dry off with a lint free cloth and apply a light coat of cooking oil to preserve the finish.

## **GENERAL INFORMATION**

### **GRILLING**

Turn the oven thermostat to a reasonably high setting and this will give a greater temperature at the top of the main oven. The flue gases are passing over the top face of this oven, so this face is being heated on both sides. The roasting tin supplied with the cooker contains a grill rack. Place any foods that require grilling onto the rack, and place the roasting tin as near to the top of the oven as possible. For any gratin type recipe that requires browning, place the dish on a shelf as near to the top of the oven as it will allow. For a delicious breakfast, lightly grease the base of the roasting tin and place slices of bread with a hole cut out of the centre, onto the base, carefully breaking an egg into each hole. Foods such as mushrooms and halved tomatoes can be placed around the eggs. Place the grilling rack over the eggs and lay the bacon, sausage, black pudding etc., onto the grilling rack. The fat will drop onto the eggs, helping to cook and flavour them. Fatty foods such as lamb cutlets are best suited to this method of oven grilling, most of the fats are drawn out into the roasting tin. Certain foods with little fat, benefit from pan frying/dry frying, using a ribbed frying or griddle pan. The foods cooked this way look attractive with the bar markings from the pan.

### **THE CARE OF YOUR COOKER**

The vitreous enamel finish on your cooker is tough and hard wearing but should be treated with care. Acidic spills on the hob should be wiped off with a clean damp cloth. The vitreous enamel front, sides and hob only need a wipe with a warm soapy cloth, then a polish with a dry one. Do not use an abrasive cleaning material on the vitreous enamel. If there are stubborn marks on the hob, use a good quality enamel cleaner. Look for cleansers carrying the VEA (Vitreous Enamel Association) Follow the manufacturer's instructions carefully. The hotplate will carbonise any food spilt on it, which should be removed with a wire brush or metal scraper. This will ensure a good contact between cooking utensil and the hotplate. Take care when cleaning the insulating lids, the hotplate may be hot. The ovens are self-cleaning, any food that spills on the oven floors will carbonise and can be brushed or scraped away. It is often easier to use the vacuum cleaner to remove all the bits.

## COOKWARE

You do not have to rush out and buy a new set of pans when you take delivery of your new Rayburn cooker, but it is advisable to check your cookware. Thin, lightweight saucepans are liable to buckle, so it is recommended that you use saucepans which have a flat, thermic base. This design of saucepan will give you complete contact with the hotplate and maximum heat retention for a good cooking performance. This design is usually of 18/20 stainless steel, with the thermic base encapsulated onto the bottom of the pan. The base will have a core of aluminium sandwiched between two layers of stainless steel. The aluminium does not come into contact with the food while cooking, but will very quickly pick up the heat and evenly distribute it over the base of the pan. Some continental designs of saucepans will have this inner sandwich of aluminium, not only at the base but up the sides as well. Many people prefer the look of cast iron cookware. This cookware is just as versatile as stainless steel, absorbing and distributing the heat evenly, and serving from the oven to table. They are available in a range of colours and designs, some with knobs and handles of a heat resistant material. Good quality saucepans can be expensive to buy, but the versatility they offer means that fewer items need to be purchased. Oven proof earthenware will also produce satisfactory results. Your traditional cake tins, baking trays, loaf tins and any other favourite ovenware you use, will be suitable. There is a bakeware on the market of Continental design which has a steel base, ideal for quickly absorbing the heat. It is covered with a magnum (enamel like) coating, which is safe to cut on, non-stick effect and easy to clean. A roasting tin, containing the grilling rack is provided. You can use a pressure cooker on the hotplate but however, do check that the base of the pressure cooker makes good contact with the hotplate.

All timings are guidelines only, as there are no set rules for roasting meat - each cut lends itself to several different ways of preparation and cooking and each family will have a preference. When meat is roasted quickly the juices are sealed in, preserving the full flavour, but there will sometimes be shrinkage. Slow roast at a lower temperature method will reduce shrinkage and give a more tender joint.

Whichever roasting method you choose, the joint should first be weighed to calculate the cooking time. Place the meat on the grilling rack in the roasting tin, fat side uppermost. This will baste the meat as it is cooking, but check the roast from time to time and using a metal spoon, baste the meat yourself.

If you are using a meat thermometer, do take care when inserting it that it does not touch bone or excess fat. This will give you a false internal reading.

Stuffed joints of meat will need extra cooking time - approximately 10 minutes more for every 500g

## RECIPE NOTES

Eggs used are size 3 unless otherwise stated. All herbs used are fresh unless otherwise stated. If unavailable use dried herbs in half the quantity stated. Milk should be full-fat unless otherwise stated. Spoon measures are level unless otherwise stated.

<b>TYPE OF MEAT</b>	<b>TEMPERATURE</b>	<b>TIMING per 500g (1 lb)</b>
BEEF ON THE BONE SIRLOIN FORE RIB	180oC	RARE 10 mins + 10 mins over MED 12mins + 12 mins over WELL DONE 20 mins + 20 mins over
BEEF BONED AND ROLLED TOPSIDE TOP RUMP FILLET ROLLED RIB	180oC	RARE 12 mins + 12 mins over  MED 15 mins + 15 mins over WELL DONE 20 mins + 20 mins over
PORK ON THE BONE SHOULDER LOIN LEG	180oC	25 mins + 25 mins over
PORK BONED AND ROLLED SHOULDER LOIN LEG	180oC	30 mins + 30 mins over
LAMB ON THE BONE CROWN GUARD OF HONOUR LEG BEST END LOIN	180oC	MED 20 mins + 20 mins over WELL DONE 25 mins + 25 mins over
LAMB BONED AND ROLLED	180oC	MED 25 mins + 25 mins over WELL DONE 30 mins + 30 mins over
VEAL BONED AND ROLLED TOPSIDE SHOULDER FILLET	180oC	MED 20 mins + 20 mins over WELL DONE 25 mins + 25 mins over
VENISON ON THE BONE HAUNCH (LEG) SADDLE	180oC	RARE 12 mins + 12 mins over MED 15 mins + 15 mins over WELL DONE 20 mins + 20 mins over
RABBIT/HARE CHICKEN	180oC 190oC	Up to 1 kg (2 lb): 45 - 60 mins Up to 2 kg (4 1/2 lb): 60 - 90 mins 20 mins + 20 mins over
TURKEY 3.6 - 4.5 kg (8 - 10 lb) 4.9 - 5.4 kg (11 - 12 lb) 5.4 - 6.3 kg (12 - 14 lb) 6.3 - 7.2 kg (14 - 16 lb) 7.2 - 8.1 kg (16 - 18 lb) 8.1 - 9 kg (18 - 20 lb) DUCK GOOSE PHEASANT GROUSE PARTRIDGE	160oC 200oC 180oC 200oC 220oC 220oC	3 1/2 - 3 3/4 hrs 3 3/4 - 4 hrs 4 - 4 1/2 4 1/4 - 4 1/2 hrs 4 1/2 - 4 3/4 hrs 4 3/4 - 5 hrs MED 25 mins + 25 mins over WELL DONE 30 mins + 30 mins over 20 mins + 20 mins over 50 - 60 mins total cooking 30 - 45 mins total cooking 45 mins total cooking



## USER COOKING TIPS

You will soon come to look upon the Rayburn as a reliable companion to help you during a busy baking session or when you are preparing that extra-special meal. The following tips are ways in which you will find the Rayburn invaluable: no doubt you will quickly add discoveries of your own to the list.

1. Baking: If you are using butter or margarine from the refrigerator, simply place the required amount of fat in a heatproof bowl on the hob, near to the hotplate. It will be quickly brought to room temperature, making it easier to work with.
2. Breadmaking: Stand the required liquid for the recipe in a heatproof jug on the hob near the hotplate to warm. Take care not to overheat as yeast is killed at high temperatures.
3. Breadmaking: Depending on what mode the cooker is set at, the hob, plate rack or lower oven can be used for proving the dough.
4. Baking: To dissolve gelatine, place two tablespoons of water or liquid from the recipe in a small heatproof bowl. Sprinkle the required amount of gelatine on the liquid and place on or near the hotplate to dissolve. A small stainless steel bowl is useful for this type of job.
5. Baking: When melted chocolate is needed in a recipe or for decoration work, simply place the chocolate in a heatproof bowl near the hotplate. This method is easier than placing over a pan of hot water, which can often splash into the chocolate and spoil it.
6. Baking: Syrup tins and jam jars with only a little left in them are easier to empty when they have warmed on the hob.
7. Cooking: If a recipe requires a small amount of fried or softened onion, place the finely chopped onion and a little butter or oil in a heatproof bowl on or near the hotplate to soften. I use this method often, because it is so much easier than having to wash up a frying-pan! Many different types of vegetables can be prepared this way before adding to a recipe.
8. Cooking: To make breadcrumbs, simply place the bread on a baking sheet in the lower oven and allow to dry out. Crush and store for future use.
9. Cooking: To make croutons, cut the bread into small cubes, place in a shallow cast iron dish with a little oil and fry, using the base of the main oven. (If the oven is not in use, fry on the hotplate) Drain, spread out on a baking sheet and put to crisp in the lower oven. Croutons can be frozen for use when required.
10. Drying: An abundance of fresh herbs need not be wasted. Place on a baking sheet, after washing and patting dry with kitchen paper, and leave to dry in the lower oven. Store for future use.
11. Drying: Cooker rice can be spread out on a baking sheet and left to dry in the lower oven.
12. Baking: When making fruit cakes, wash the dried fruit, place on a baking sheet and allow to dry off in the lower oven before use. Moist fruit will sink to the bottom of a cake and spoil it.
13. Preserving: When you are bottling, the depth of the main oven makes it easy to sit a tray of bottled fruit all on the same shelf to cook in one session.
14. Preserving: When you are making jam the graduated hotplate enables you to control the simmering of a large preserving pan much more easily than on a conventional cooker, where the pan is too large for the burner or ring. The warming of sugar, drying of the prepared fruit and the warming of jars and bottles can all be done with plenty of space using the lower oven and plate rack, if you have one.

## FAULT FINDINGS

PROBLEM	CAUSE	REMEDY
Poor Flue Draught:	Obstruction.	Clear and clean.
	Chimney too low.	Raise height above ridge.
	Chimney too wide.	Fit flue liner 150mm (6")
	Crack in wall.	Repair cracks.
	No flue liner	Fit flue liner
Excessive Flue Draught	High chimney.	Fit draught stabiliser venting to the outside atmosphere.
Down Draught:	High trees	Raise chimney height.
	High buildings	Raise chimney height.
	Low chimney	Raise chimney height.
	Positive pressure zone.	Check flue termination
Cooker Smoking	Insufficient primary air.	Provide additional room air inlet or adjust burner air intake.
	Chimney choked.	Clean chimney.
	Downdraught.	Raise chimney height.
	Poor combustion.	Check air supply.
Hot Plate Not Heating	Burner cutting out.	Increase cooker thermostat setting.
	Utensils not flat.	Use machined based utensils.
Radiators Not Heating	Circulating pump not working.	Check and replace if defective.
	(b) Room thermostat set too low	Increase setting
	(c) Air in system.	Bleed system.
	(d) Pipe system faulty.	Check pipe sizes and circuit.
	(e) Excessive number of radiators	Turn off un-needed radiators.
	(f) Radiator valves not balanced	Adjust valves to give an even flow.
	(g) By-pass incorrectly set.	Adjust by-pass valve
8. Domestic Hot Water Cylinder not getting hot enough:	Cylinder too large	Use 180 litre cylinder
	Flow pipe too large	Use 28mm bore pipe.
	'Balancing valve' is closed.	Open 'balancing valve'.
	(d) Cylinder thermostat set too low	Increase thermostat setting.
	(e) Circulating pump not working	Check and replace if defective.
	(f) Motorised valve not opening	Check and replace if defective.
9. Intermittent Performance	Cooker starved of primary air.	Provide air inlet in room.
	(b) Extraction fan in room.	Provide additional air inlet in room.
	(c) Dirt in nozzle	Clean or replace nozzle.
	(d) Dirty burner	Service burner.
	(e) Faulty Thermistor/Thermocouple	Replace if defective.
	(f) Dirty flueways.	Clean flueways
	(g) Dirty Oil Filter	Clean or replace
	(h) Worn nozzle	Replace nozzle
10. Domestic Hot Water Rusty	Leak in indirect cylinder.	Replace cylinder.
	Incorrect cylinder fitted.	Check with installer.

It is of the utmost importance to keep the flue pipe and chimney clear of deposits. Blocked or partially obstructed flueways and chimneys will cause dangerous fumes to be emitted into the room, these may well be invisible.

## 5. Installation Introduction

---

Congratulations on purchasing this fine Oil-fired Central Heating Cooker. It is built to exacting standards and it will give you every satisfaction in use.

Please read the following information before operating this excellent product.

This appliance is hot while in operation and retains its heat for a long period of time after use. Children, aged or infirm persons should be supervised at all times and should not be allowed to touch the hot working surfaces while in use or until the appliance has thoroughly cooled.

To ensure safety, satisfaction and reliable operation, this quality cooker should be installed by a trained and competent person. The central heating facility and the hot water systems involved must conform fully to good plumbing practice, established Standards/Regulations and OFTEC recommendations.

As manufacturers and suppliers of cooking and heating appliances, we take every possible care to ensure, as reasonably practicable, that these appliances are so designed and constructed as to meet the general safety requirements when properly used and installed.

- Section 10 of the Consumer Protection Act 1987.
- Safety, Health and Welfare at Work Act.

The complete installation must be done in accordance with current Standards and Local Codes. It should be noted that the requirements and these publications may be superseded during the life of this manual.

### **IMPORTANT — Control of Substances Harmful to Health:**

It is the Users/Installers responsibility to ensure that the necessary personal protective clothing is worn when handling materials that could be interpreted as being injurious to health and safety.

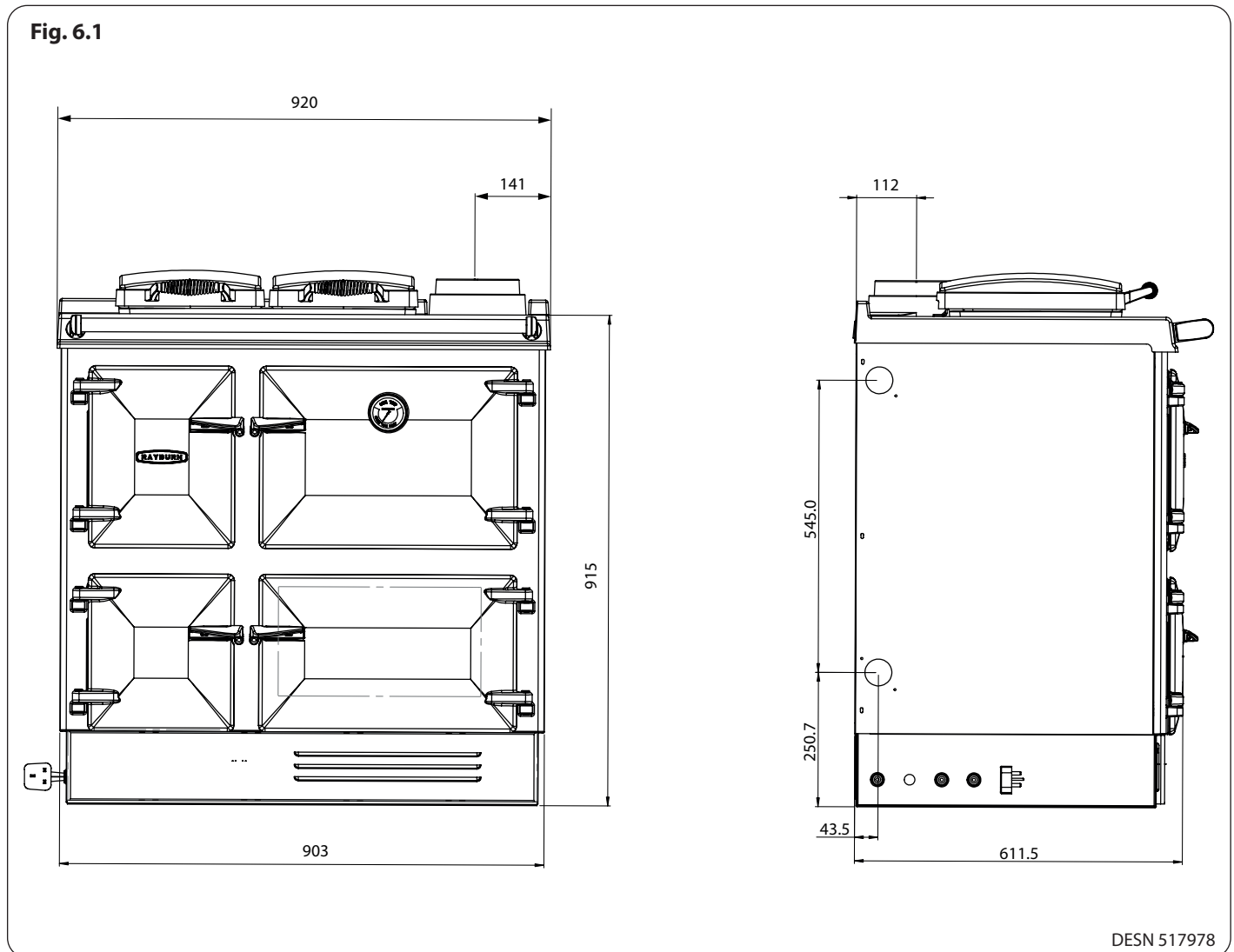
When handling Firebricks, Fire Cement or Fuels, use disposable gloves.

Exercise caution and use disposable masks and gloves when handling glues and sealants.

When working with fibre glass, mineral wool, insulation materials, ceramic blanket/board or kerosene fuel oil, avoid inhalation as it may be harmful. Avoid contact with skin, eyes, nose and throat. Use disposable protection.

Installation should be carried out in a well ventilated area.

## 6. Product Dimensions Rayburn Heatranger®



**NOTE:** When surveying for a appliance installation the actual clearance required for the 'body' of the appliance should be increased overall by 10 mm beyond the figures quoted above. This allows safe margin to take into account the natural dimensional variations found in major castings in particular the width across an appliance recess could be critical.

FEATURE	METRIC (mm)
Hot Plate	550W x 323L
Roasting Oven	390W x 310H x 406D
Simmering Oven	390W x 220H x 406D

## 7. Technical Data

FUEL:	28 Sec Kerosene
MAINS CURRENT:	230v - 240v, 50 Hz A.C.
I.P. PROTECTION:	IP 20
ELECTRICAL INPUT:	90 Watts
SUPPLY FUSE RATING:	5A
MAX BOILER WORKING PRESSURE:	1.9 bar 27.3 P.S.I.
TEST PRESSURE OF BOILER:	3 bar 43.5 P.S.I.
OPERATING TEMPERATURE LIMIT IN BOILER:	96°C (205°F)
<b>100K</b>	
BOILER OUTPUTS:	29.3kW - 100,000 Btu's/Hr.
RADIATOR SURFACE:	53 m <sup>2</sup> (571 ft. <sup>2</sup> ) heating surface only. 48 m <sup>2</sup> (514 ft. <sup>2</sup> ) heating surface and domestic hot water.
FLUE GAS FLOW:	Boiler: 0.005m <sup>3</sup> /s Oven: 0.0026m <sup>3</sup> /s.
SPACE HEATING:	2.91 kW (10,000 Btu's/hr) cooking mode 0.7 kW (2,500 Btu's/hr) boiler mode.
FLUE GAS TEMPERATURE:	Boiler: 180°C (356°F) Cooker: 250°C. (482°F)
BOILER CAPACITY:	17 litres (3.74 Gal.).
BOILER MATERIAL:	Mild steel.
COOKER WEIGHT:	385Kg (850 lbs).
<b>80K</b>	
BOILER OUTPUTS:	23.45kW - 80,000 Btu's/Hr.
RADIATOR SURFACE:	42.5 m <sup>2</sup> (457 ft. <sup>2</sup> ) heating surface only. 37.2 m <sup>2</sup> (400 ft. <sup>2</sup> ) heating surface and domestic hot water.
FLUE GAS FLOW:	Boiler: 0.0044m <sup>3</sup> /s Oven: 0.0026m <sup>3</sup> /s.
SPACE HEATING:	2.91 kW (10,000 Btu's/hr) cooking mode 0.7 kW (2,500 Btu's/hr) boiler mode.
FLUE GAS TEMPERATURE:	Boiler: 200°C (392°F) Cooker: 230°C. (446°F)
BOILER CAPACITY:	17 litres (3.74 Gal.).
BOILER MATERIAL:	Mild Steel.
COOKER WEIGHT:	380Kg (838 lbs).
<b>60K</b>	
BOILER OUTPUTS:	17.58kW - 60,000 Btu's/Hr.
RADIATOR SURFACE:	32 m <sup>2</sup> (344.45 ft. <sup>2</sup> ) heating surface only. 26.5 m <sup>2</sup> (285 ft. <sup>2</sup> ) heating surface and domestic hot water.
FLUE GAS FLOW:	Boiler: 0.0031m <sup>3</sup> /s Oven: 0.0026m <sup>3</sup> /s.
SPACE HEATING:	2.91 kW (10,000 Btu's/hr) cooking mode 0.7 kW (2,500 Btu's/hr) boiler mode.
FLUE GAS TEMPERATURE:	Boiler: 170°C (356°F) Cooker: 250°C. (482°F)
BOILER CAPACITY:	17 litres (3.74 Gal.).
BOILER MATERIAL:	Mild Steel.
COOKER WEIGHT:	385Kg (850 lbs)

**THIS APPLIANCE MUST BE CONNECTED TO A FULLY PUMPED SYSTEM.**

**BURNER SPECIFICATION**

Burner Input				COOKER BURNER
	100K	80K	60K	100K/80K/60K
(kW) Continuous Running	34.2	27.7	21.4	19.5
(kW) Cycling	N/A	N/A	N/A	4.4
(Btu's) Continuous Running	116,760	94,600	73,000	66,875
(Btu's) Cycling	N/A	N/A	N/A	14,950

**Boiler Output**

	100K	80K	60K	100K/80K/60K
(kW) Continuous Running	29.3	23.5	17.6	2.1
(kW) Mean Cycling	N/A	N/A	N/A	1.2
(Btu's) Continuous Running	100,000	80,000	60,000	7,000
(Btu's) Mean Cycling	N/A	N/A	N/A	4,000
Nozzle	0.85 80°S (C.E.N)	0.65 80°S (C.E.N)	0.55 80°S (C.E.N)	0.5 60°S (C.E.N)

**Pressure**

	100K	80K	60K	100K/80K/60K
(Bar)	7.4	7.4	7.1	7.5
(PSI)	107	108	103	110

**Fuel Consumption**

	100K	80K	60K	100K/80K/60K
(L/Hr) Continuous Running	3.6	2.9	2.2	2.1
(L/Hr) Cycling	N/A	N/A	N/A	0.47
US Gal/Hr				
Continuous Running	0.95	0.77	0.58	0.55
US Gal/Hr Cycling	N/A	N/A	N/A	0.12

All data are taken under laboratory conditions and may vary in use.

**Differential Pressure Across the Boiler**

Design flow rate through the boiler	38.2 L/min / 8.4 Gpm
Static differential across the boiler	52.4 mbar / 21" wg
Dynamic pressure differential across the boiler	33 mbar / 13.23" wg

Boiler		Cooker	
Air Setting	CO <sup>2</sup> %	Air Setting	CO <sup>2</sup> %
9	11.5	5	10
8	11.8	4	10.34
7	11.9	3	10.8
6	12.2	2	11.2

Find the correct position of the air control, which gives the highest reading of CO<sup>2</sup> within the range of the table without exceeding a smoke No. 0-1 (Bacharach Scale).

**Note: Design temperature differential across the boiler = 11°C (52°F)**

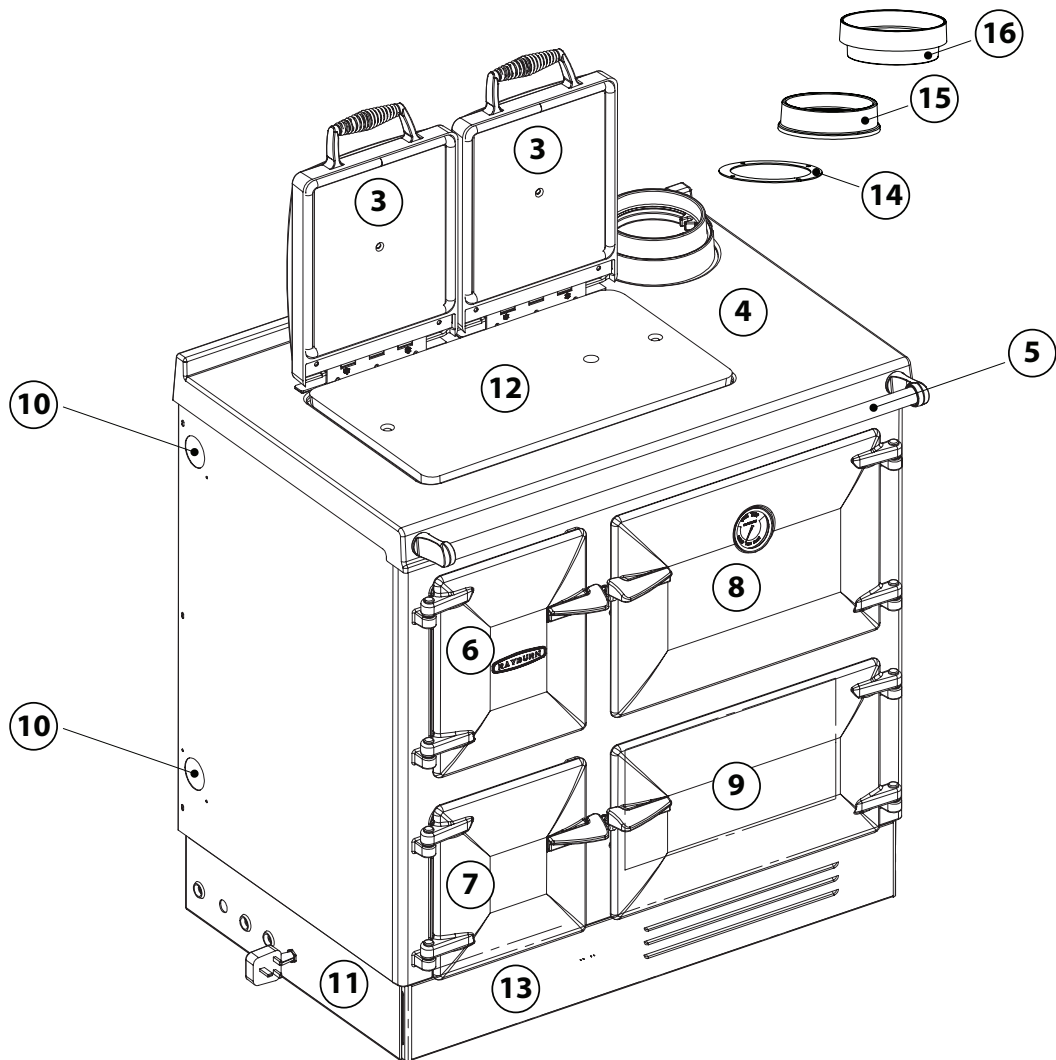
The installation must comply with the current editions of the following:

- BS 5410: Oil Installations Part 1 under 45kW.
- The Building Regulations: Part J England, Wales,
- Part F Section 4 Scotland, Part L Northern Ireland and Part J Ireland.

The Control of Pollution (Oil) Regulations.

- BS 5449: Forced circulation hot water central heating systems for domestic installations.

- Health and Safety at Work Act.
- BS 7671: Requirements for Electrical Regulations. Safety Document 635: The Electricity at Work Regulations.
- BS 7593: Treatment of Water in Domestic Hot Water Systems.
- BS 7074 Part 1 & 2: Hot Water Supply.
- BS 4814: Sealed System.



DESN 517980

- |                          |   |
|--------------------------|---|
| 1. Platerack (to order)  | 9. Simmer Oven Door                       |
| 2. Splashback (to order) | 10. Boiler Tappings                       |
| 3. Hotplate Covers       | 11. Base Frame                            |
| 4. Hob                   | 12. Hotplate                              |
| 5. Towel Rail            | 13. Plinth                                |
| 6. Firedoor              | 14. Gasket                                |
| 7. Burner Door           | 15. Flue Adapter 125mm (5") or 150mm (6") |
| 8. Main Oven Door        | 16. Flue Collar 125mm (5") or 150mm (6")  |

## 8. Installation Process

### LOCATION

When choosing a location for this appliance you must have:

- Sufficient room for the installation (see clearances), a satisfactory flue (see flue system), and an adequate air supply for correct combustion and operation (see Ventilation and Combustion air supply).
- Adequate space for maintenance and air circulation.
- Solid floor or base of non-combustible material which is capable of supporting the total weight. (see Technical Data).

Note: Installation should be carried out in a well ventilated area.

### HEARTH CONSTRUCTION

When a non-combustible floor surface is not available, then the cooker must be placed on other insulating material. We recommend a slab of precast concrete 40mm (1½ inches) deep. If other insulating material is being used, the dimensions of the slab of this insulating material must afford similar protection. This hearth must extend 150mm (6 inches) to either side of the appliances and 225mm (9 inches) to the front.

### ELECTRICAL SUPPLY

All wiring external to the appliance must conform to the current BS 7671 (U.K.), & Safety Document 635, ETC: Part 1 Section 5.6.4. The Electricity at Work Regulations. The cooker requires a 230V–240V, 50 Hz supply. Connection of the appliance and any system controls to the mains supply must be through a moulded on plug top, (which is fitted with a 5 amp fuse) which is fitted to the appliance in accordance with EN 60335, Consumer Protection, SI 1994 No. 1768, plug and sockets etc. (safety) Regulations 1994.

Always install in accordance with current local wiring regulations.

You should always, when either exposing or working with wiring, consult a qualified electrician.

**⚠ WARNING: THIS SUPPLY MUST BE EARTHED**  
(Refer to B.S. 7430: Code for Practice of Earthing)

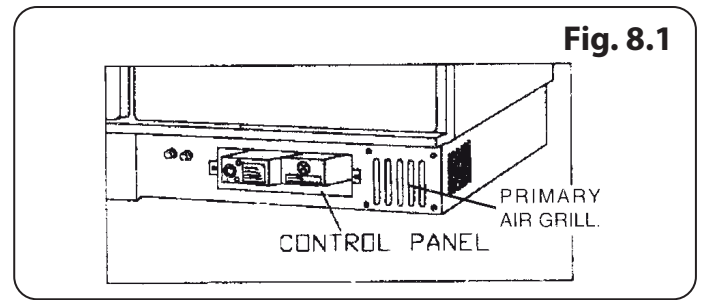
Where a risk of low voltage can occur, a voltage sensitive device should be fitted to prevent start-up of the burner so as not to endanger the installation.

The primary fuse is located in the control box tray.

To isolate the appliance completely unplug from the mains socket. Always ensure that this socket is easily accessible and close to the appliance.

Persons in charge of this appliance should be aware of this socket outlet position.

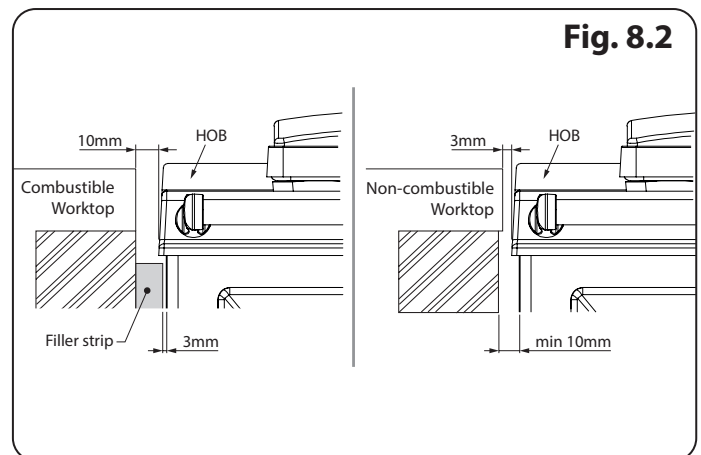
### TO ACCESS THE CONTROL PANEL (Fig. 8.1)



- The plinth can be removed by sliding it approximately 20mm to the left.
- Remove the 6 screws which hold the kicker panel in place.
- Remove the 2 retaining screws on either side of the Control Console.
- Carefully withdraw the Control Console, ensuring that no strains are subjected to the wiring.
- Connection to be carried out in accordance with the Wiring Diagrams (Fig. 8.18 to Fig. 8.21)

When bringing your kitchen units up to the sides of the cooker leave a 10mm gap between the Rayburn and adjacent units, (see Fig. 8.2). Likewise the base of your units can be brought up flush to the Rayburn's built-in plinth.

When bringing the work top up to the side of the hob leave a 10mm gap to combustible material and a 3mm gap to a non-combustible material.





Where the flue passes through a combustible material, a twin wall solid packed insulated chimney connector must be used and must come flush with the outer surface of the material and run all the way to the masonry chimney or to the point of termination of the factory made chimney.

(You should discuss the installation of your Rayburn cooker with your builder in this regard in the case of a newly fitted kitchen.

When installing a non-combustible worktop, it is necessary to allow adequate clearance for the removal of the hob.

## FLUE SYSTEMS

### PRE-INSTALLATION CHECK

Before installing the cooker, check that the chimney is clean and clear of obstructions. Cracked brickwork and leaking joints should be made good.

You must reassure yourself (with the benefit of professional advice) that the brickwork and system generally is of the standard suitable to support the cooker in a safe and efficient manner.

Where flue piping passes through a closure plate with a sliding door, ensure that the pipe continues up and is ultimately connected to the flue liner and well-sealed with fire cement.

Do not connect to a flue serving another appliance. Always ensure that the connection is to a chimney of the same size - never connect to one of smaller dimensions. Flues wholly constructed of single skin pipe are not recommended under any circumstances. Due to their inability to retain heat such flues will inevitably give rise to the formation of condensation.

**IT IS NOT RECOMMENDED TO CONNECT TO A FLUE SMALLER THAN 125mm (5") OR IN EXCESS OF 175mm (7") DIAMETER.**

### 125mm (5") Diameter Flue Liner

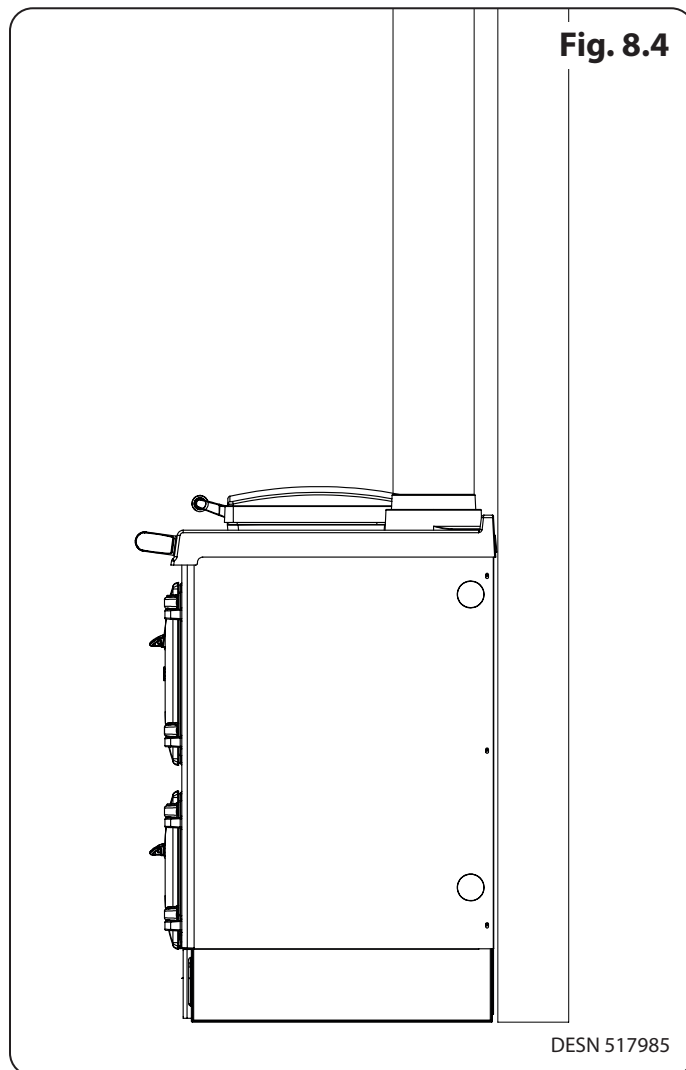
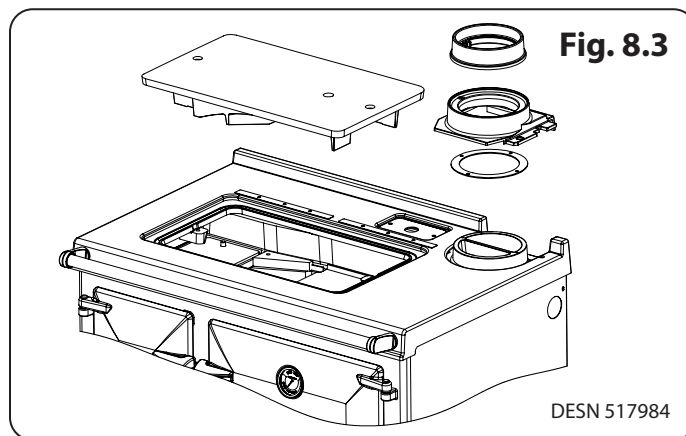
### CHIMNEY

Generally the most effective chimney for oil is one that is straight, avoid offsets and terminate with a straight sided pot.

### SEALING

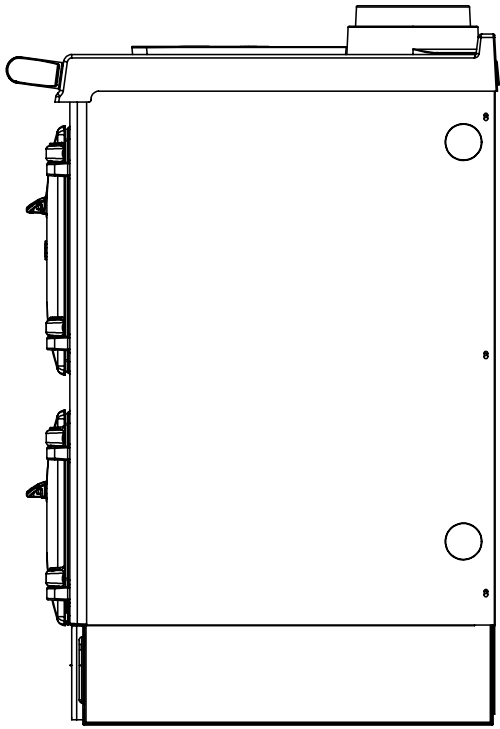
This cooker and flue system operate under a positive pressure. It is essential that all flue joints are tightly sealed against flue gas leakage and tested accordingly. (See **Fig. 8.3**, **Fig. 8.4**, **Fig. 8.5**, **Fig. 8.6** & **Fig. 8.7**)

There is a flue pipe collar available which surrounds the flue pipe where it meets the wall, giving a tidier finish to a tiled background.



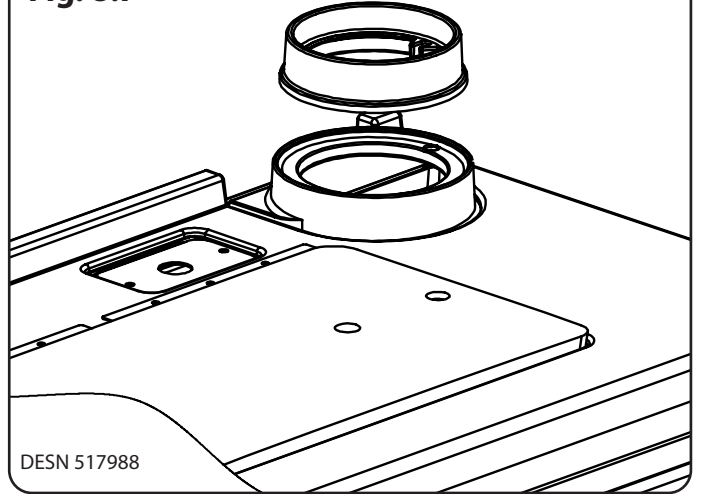
Flue greater than 125mm (5") Diameter

**Fig. 8.5**



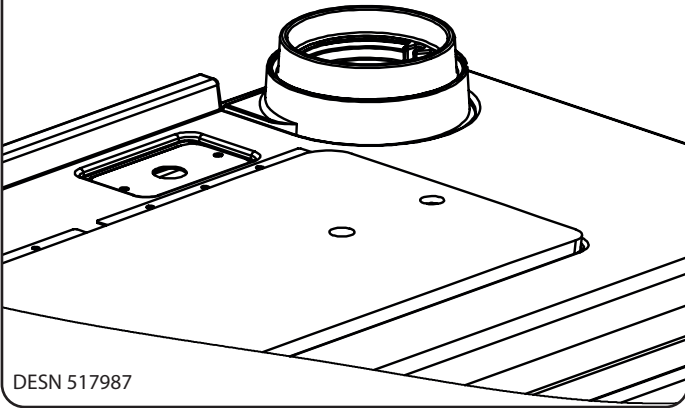
DESN 517986

**Fig. 8.7**



DESN 517988

**Fig. 8.6**



DESN 517987

## FLUE HEIGHT

The flue must be high enough 4.5 mts (15ft) minimum measured vertically from the appliance outlet to the top of the flue terminal to allow the flue gases to vent into the clear air, away from the turbulence that may be caused by roof structures, other chimney stacks, etc. The terminal position should be in accordance with the relevant Building Regulations.

## FLUE SYSTEM

Where the standard masonry chimney is not available, a proprietary type of non-combustible or non-corrosive material 150mm (6") twin wall fully insulated pipe may be used. The pipe must terminate at a point not lower than the main ridge or adjacent outside obstructions. With such installations, access to the chimney must be provided for cleaning purposes.

### **ALL FLUE CONNECTIONS MUST BE THOROUGHLY SEALED.**

Blocked chimneys are dangerous, keep chimneys and flue ways clean, read the operating instructions.

### **RAYBURN CAST IRON PIPES AND BENDS ARE HIGHLY RECOMMENDED FOR INTERIOR USE.**

**WHERE THE APPLIANCE SPIGOT OR FLUE PIPE PROTRUDES INTO THE CHIMNEY, CARE SHOULD BE TAKEN TO ENSURE THAT IT DOES NOT BLOCK THE CHIMNEY.**

## SUITABLE MATERIALS

- Mineral Fibre cement pipes.
- Insulated metal chimneys conforming to B.S. 4543. (a galvanised finish is not suitable for exterior use).
- Clay flue linings.
- Pre-cast concrete chimney blocks, incorporated into the building structure. It is particularly important that the correct connection block be provided at the base of the flue.
- Cast iron or acid resistant vitreous enamel lined mild steel to B.S. 41.
- Sheet metal.

## FLUE CLEANING

The flue pipe must be fitted with a cleaning plate.

The flue must be inspected annually and cleaned when necessary.

## USE OF EXISTING FLUES AND CHIMNEYS

When connecting to an existing chimney it is necessary to line the flue using approved 150mm (6") rigid or flexible stainless steel flue liner.

An existing flue pipe or chimney that has proved to be satisfactory when used for solid fuel can normally be used for this appliance provided that its construction, condition and dimensions are acceptable. Flues that have proved to be unsatisfactory, particularly with regard to down draught, must not be considered for this appliance until they have

been examined and any faults corrected. If there is any doubt about an existing chimney a smoke test should be carried out.

Before connecting this appliance to a chimney or flue pipe which has previously been used with another fuel, the chimney or flue pipe should be thoroughly swept and lined accordingly.

All register plates, restricter plates and dampers etc. which could obstruct the flue at a future date should be removed before connecting this appliance.

Where a chimney is not required to be lined a suitable void should be provided at the base to contain any debris which might fall from the inside wall, so as to prevent debris from obstructing the appliance flue outlet. (Removal of debris should be facilitated by the provision of an access door).

This void should have a depth of not less than 250mm (10") below the appliance connection.

The combustion products will have a descaling effect on hardened soot deposits left from burning solid fuels.

**ALTHOUGH THE CHIMNEY MAY HAVE BEEN CLEANED OF LOOSE SOOT PRIOR TO INSTALLATION, IT IS IMPERATIVE THAT THE CHIMNEY IS INSPECTED FOR SCALED SOOT PARTICLES AFTER THE FIRST MONTH OF OPERATION AND ANY LOOSE MATERIALS REMOVED TO AVOID BLOCKAGE.**

## DRAUGHT REQUIREMENTS

While inadequate draught can seriously effect the efficient operation of the appliance, chimney's over 5.4m (18ft) for houses built on high ground can experience excessive draught. A steady draught of between 1mm (.04) and 1.5mm (.06) inches W.G. is required for satisfactory operation.

## FLUE LINERS

Chimney's lined with salt glazed earthenware pipes are acceptable if the pipes comply with BS EN 1457 and must be 150mm (6"). When lining an existing chimney, a liner approved to BS 4543, Parts 1, 2, 3 & 4 should be used. The liner should be secured at the top and bottom by using closure/clamping plate firmly sealed and secured and an approved low resistance terminal used at the top.

It is essential that every flue system be inspected and tested by a competent person for its correct effectiveness, to ensure that the combustion products are completely discharged to the outside atmosphere.

## FACTORY MADE INSULATED CHIMNEYS

Factory-made insulated chimneys should be constructed and tested to meet the relevant standards and recommendations given in:

- B.S. 7566 - Installation of factory-made chimneys conforming to B.S. 4543 for domestic appliances.
- Part 1: Method of specifying installations design information.
- Part 2: Specification for installation design.
- Part 3: Specification for site installation.
- Part 4: Recommendation for installation design and installation.

## VENTILATION & COMBUSTION AIR REQUIREMENTS

1. It is imperative that there is sufficient air supply to the burners of the cooker in order to support correct combustion.
2. The air supply to this appliance must comply with BS 5410 Part 1.
3. The minimum effective air requirement for this appliance is 215 cm<sup>2</sup> (100), 193 cm<sup>2</sup> (80) or 155cm<sup>2</sup> (60). When calculating combustion air requirements for this appliance use the following equation: 550mm<sup>2</sup> per kW of maximum rated output above 5kW. These requirements are illustrated in OFTEC Technical Book No. 3 & B.S. 5410.
4. If there is another appliance using air fitted in the same or adjacent room, it will be necessary to refer to B.S. 5410 to calculate the additional air supply.
5. All materials used in the manufacture of air vents should be such that the vent is dimensionally stable and corrosion resistant.
6. Air vents direct to the outside of the building should be located so that any air current produced will not pass through normally occupied areas of the room. An air vent outside the building should not be located less than the dimensions specified within the Building Regulations (See Technical Data) from any part of any flue terminal. These air vents must also be satisfactorily fire proofed as per Building Regulations.
7. Air vents in internal walls should not communicate with bedrooms, bedsits, toilets, bathrooms or rooms containing a shower.
8. Air vents traversing cavity walls should include a continuous duct across the cavity. The duct should be installed in such a manner as not to impair the weather resistance of the cavity.
9. Joints between air vents and outside walls should be sealed to prevent the ingress of moisture. Existing air vents should be of the correct size and unobstructed for the appliance in use.

10. If there is an air extraction fan fitted in the room or adjacent rooms where this appliance is fitted, additional air vents will be required to alleviate the possibility of spillage of combustion products from the appliance/flue while the fan is in operation. (Refer B.S. 5410).
11. Where such an installation exists, a test for spillage should be made with the fan or fans and other burning appliances in operation at full rate (i.e. extraction fans, tumble dryers) with all external doors and windows closed.
12. If spillage occurs following the above operation, an additional air vent of sufficient size to prevent this occurrence should be installed.

## OUTSIDE AIR CONNECTION

If this option is used additional air as indicated in BS 5410 is not required.

1. This appliance may be connected direct to the outside of the house for its combustion air supply.
2. Remove the blanking plate located at the back right hand corner and remove the primary air grill located at the front right hand corner. Fix the blanking plate over the front primary air inlet. (See **Fig. 8.9**)
3. Connect the optional 125mm (5") spigot to the base. (See **Fig. 8.10**).
4. To connect this appliance to an outside air supply use either 125mm (5") rigid or flexible stainless steel pipes or non-combustible corrosion-resistant materials not more than 965mm (38") in length and having no sharp bends or corners other than the down turn at the terminus.
5. Air inlets traversing cavity walls should include a continuous duct across the cavity. The duct should be installed in such a manner as not to impair the weather resistance of the cavity.
6. Joints between air vents and outside walls should be sealed to prevent ingress of moisture.

## HEATING PIPE FITTINGS

Materials used for insulation work should be fire resistant. Standards should conform to all appropriate regulations in force at the time and place of installation.

1.1 Ferrous Materials	2.2 Non-Ferrous Materials
BS 1387 Steel tubes.	EN 29453 Soft Solder Alloys.
BS 1740 Steel pipe fittings.	BS 864 Compression tube fittings.
BS 4127 Stainless steel tubes.	BS 2871 & BS EN 1057 Copper & Copper
BS 6956 Jointing Materials.	Alloys.

## DOWN DRAUGHTS

However well designed, constructed and positioned, the satisfactory performance of the flue can be adversely affected by down draught caused by nearby hills, adjacent tall buildings or trees. These can deflect wind to blow directly down the flue or create a zone of high pressure over the terminal.

A suitable anti-down draught terminal or cowl will usually effectively combat direct down blow but no cowl is likely to prevent down blow due to high pressure zone. Ensure that any cowl used will not restrict the flue exit, or cause excessive back draught. (See **Fig. 8.11**)

## WATER PIPE SIZE

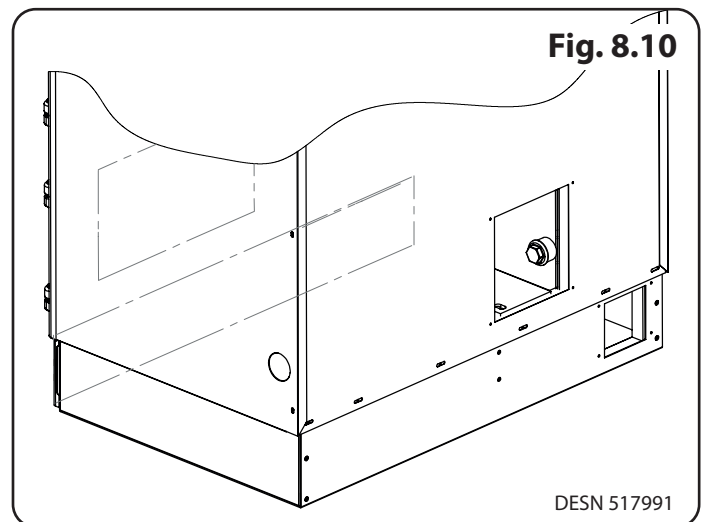
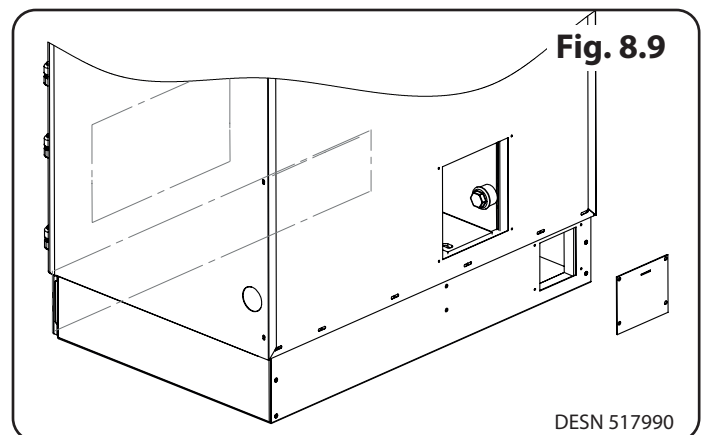
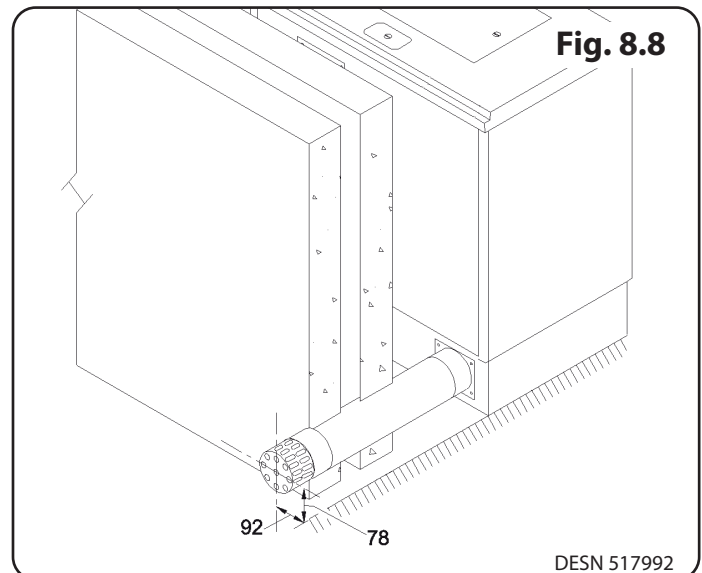
The flow and return pipe must be 28mm diameter. Care should be taken to ensure that the heating system is correctly installed and that it complies with all relevant codes of practice. If this appliance is being connected to an existing system, we strongly recommend that you engage an appropriately qualified person to check the following:

- a. That the system is sound.
- b. That pipework is adequately insulated (where applicable).
- c. Check all controls, i.e. pump, motorised valves, time control etc. are operating satisfactorily and are compatible with the requirements of the cooker.
- d. Are any modifications necessary to make the heating system more efficient?
- e. Cleanse the system and add suitable inhibitor. The use of motorised valves, room thermostats, radiator thermostatic valves, domestic hot water controllers, etc. can greatly enhance a heating system and we recommend their use.

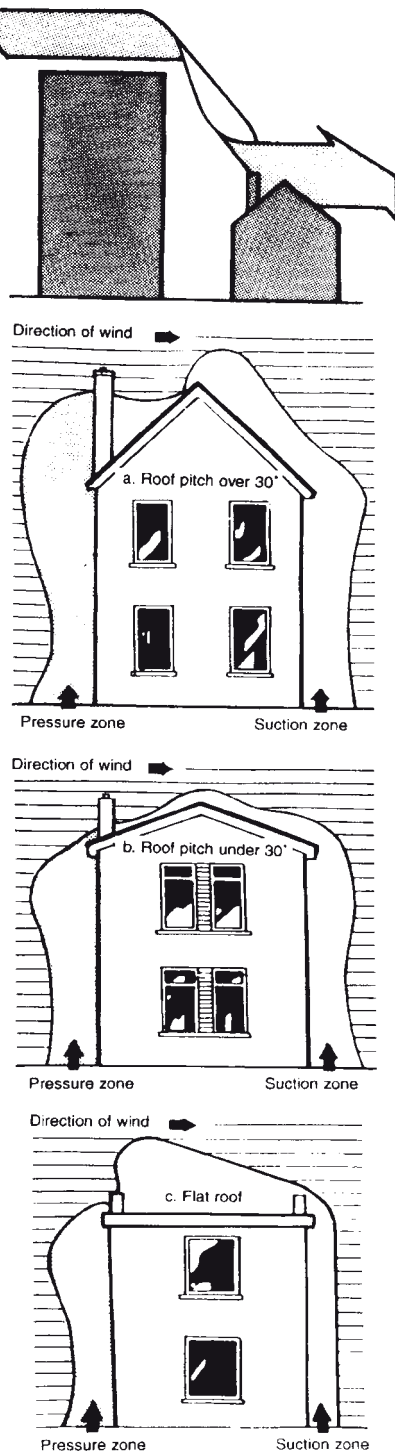
Only competent personnel should be employed to carry out your heating installation.

The flow and return can be taken either side of the cooker (**Fig. 8.9**).

1. To take off from the left simply connect directly onto the exposed boiler connection.
2. To take off from the right side:
  - a. Remove the two blanks on the right hand side of the cooker. Then remove the two cover plates from the cooker's back panel.
  - b. Remove the plugs from the boiler connections. To avoid insulation from going into the flow and return ports, cover with insulating tape.
  - c. Using copper pipe, punch out a passage way through the insulation material to the boiler connections. Clear any insulation away from the boiler connections.
  - d. Before passing the flow and return pipes through the cooker, cover the ends with tape to avoid insulation entering them.



**Fig. 8.11**



DESN 517993

- e. Remove tape from pipes and boiler ports. Connect pipes to boiler.
- f. Replace blanking plates.
- g. Plug the boiler tappings on the left hand side of the boiler with 1" BSP plugs.
- h. Test for leaks.

### **DRAINING**

Key-operated drain taps to BS 2879 should be provided in accessible positions in all low parts of the system. However, it should be noted that there may be short sections of pipework, e.g. when passing under doorways, that may not be possible to drain.

### **INTERNAL PUMP THERMOSTAT**

This appliance has the capability for switching the circulating pump 'on' and 'off' automatically. To wire in the pump, connect the phase to terminal marked CIRC Pump (L) and connect the Neutral to terminal marked CIRC Pump (N). The earth wire is to be connected into the earth block.

The connection circuit board/control panel is located within the appliance beneath the warming oven. (See **Fig. 8.1**).

### **WATER CIRCUIT TEMPERATURE**

The return water temperature should be maintained at not less than 50°C (122°F) so as to avoid condensation forming within the boiler.

### **CARE FOR YOUR CENTRAL HEATING SYSTEM**

The use of suitable corrosion inhibitors and anti freeze solution in your heating system is essential to minimise black oxide, sludge and scale build-up, which effects efficiency.

In hard water areas the use of a suitable limescale preventer / remover is advised.

Use only quantities specified by the water treatment product manufacturer. Only add to the heating system after flushing and finally refilling. Refer to BS 7953.

### **INDIRECT DOMESTIC CYLINDER**

The cooker must only be connected to an indirect cylinder of no less than 180 litres using 28mm diameter flow and return piping. It is recommended that the cylinder is lagged together with pipework with runs in excess of 4 meters (12').

## SERVICING

To ensure continued efficient and safe operation of the appliance, it is recommended that it is checked and serviced by an Authorised Service Engineer at least once a year.

### ⚠ IMPORTANT:-

Flexible oil lines should be inspected at each and every service visit. It is important in the interest of safety that flexible lines are changed at regular intervals and should be changed immediately in all the following cases:

1. The oil line has been in use in the cooker for 3 years or more.
2. The date code on the oil hose shows as five years or older. (whichever of the above comes first)
3. The oil hose shows signs of being kinked or damaged, irrespective of date life service span.

## GENERAL MAINTENANCE

It is important that the user is familiar with their heating system and that they ensure regular checks and maintenance which can limit unnecessary break-downs.

If in doubt, the user should consult an appropriately qualified person such as a plumber or heating engineer.

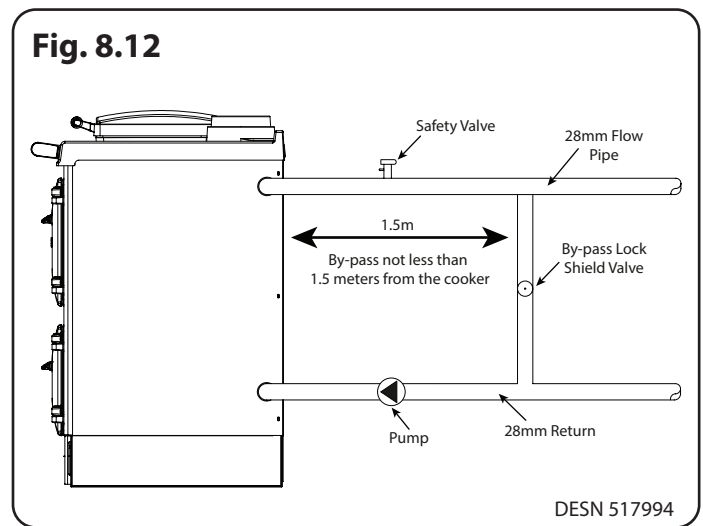
## SAFETY VALVE

A non-adjustable 3 bar safety valve must be fitted to the primary flow pipe adjacent to the boiler connection ensuring that any discharge will not create a hazard to occupants or cause damage to electrical components or property.

A 15mm system by-pass must be fitted not less than 1.5 meters (4.9ft) from the cooker to allow correct water circulation for the pump and to prevent condensation forming in the boiler. This should be balanced. A heat sink radiator / towel rail may be installed if desired in addition to the By- Pass Loop. (See **Fig. 8.12** & **Fig. 8.15**)

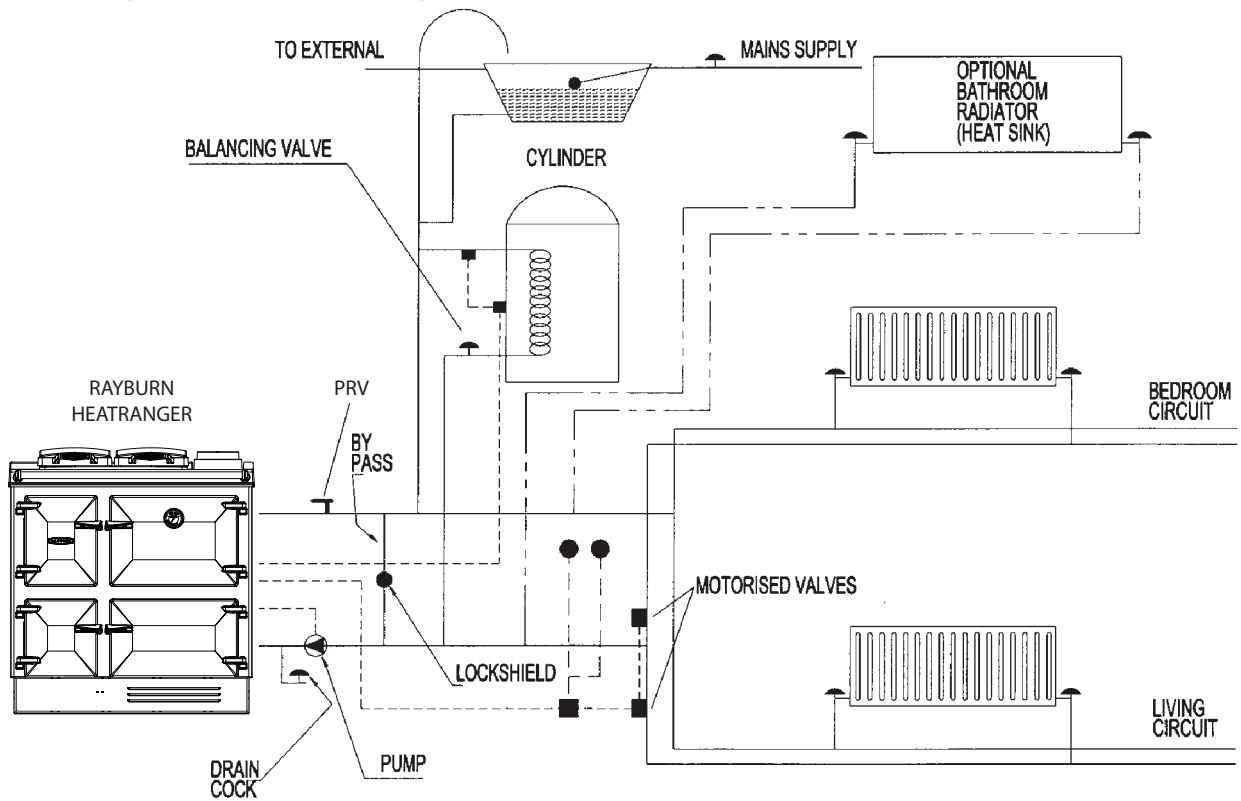
**NOTE:** We strongly advise the use of pipe lagging and also the use of a frost thermostat if the installation is likely to be exposed to situations where the temperature will dip to a level consistent with frost.

The following diagrams illustrate the different types of central heating systems to which this appliance can be connected, but are not to be used as working drawings.

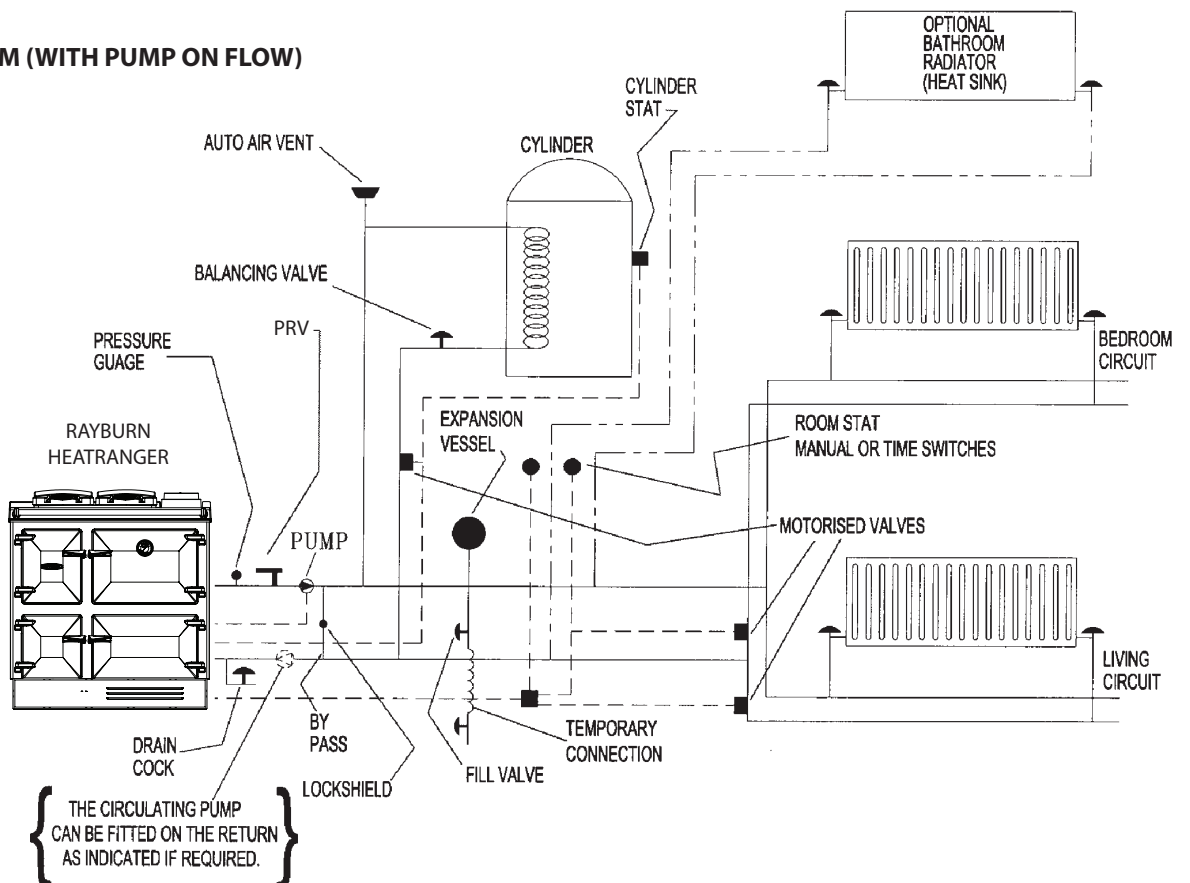


**Fig. 8.13**

**OPEN SYSTEM (WITH PUMP ON RETURN)**



**SEALED SYSTEM (WITH PUMP ON FLOW)**

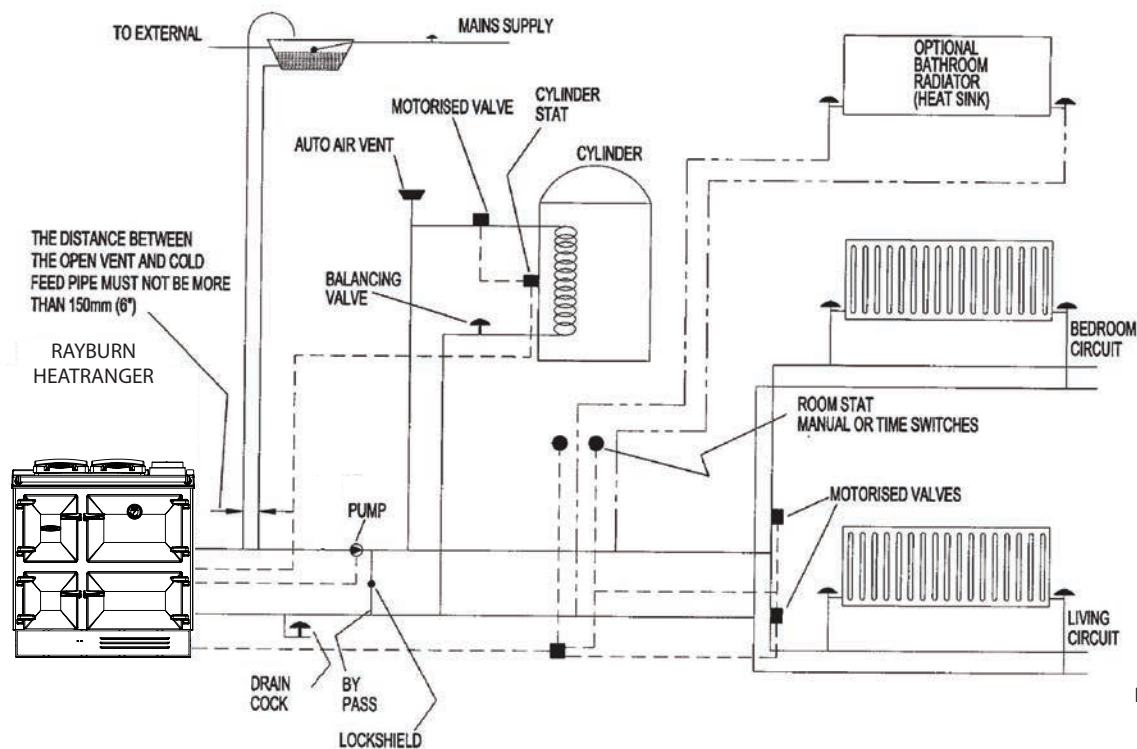


DESN 517995

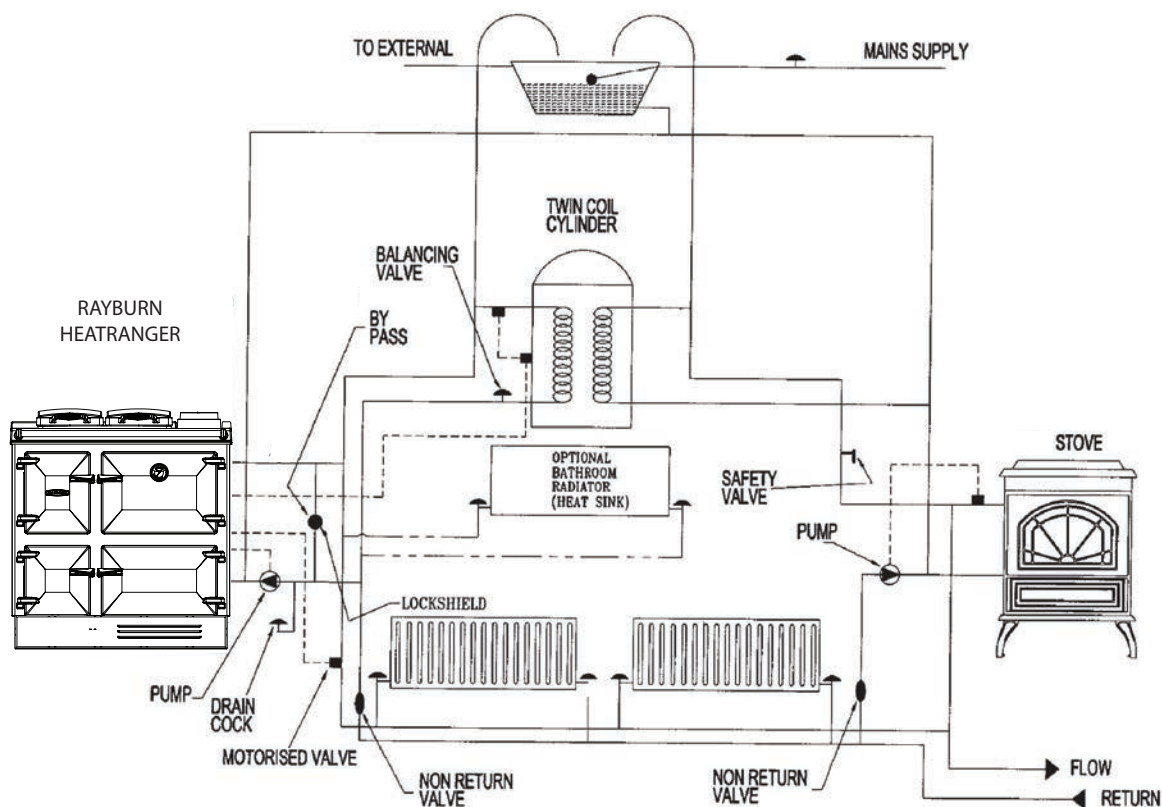


Fig. 8.14

PIPE LAYOUT —————  
 WIRING LAYOUT - - - - -  
 OPTIONAL PIPE LAYOUT - - - - -

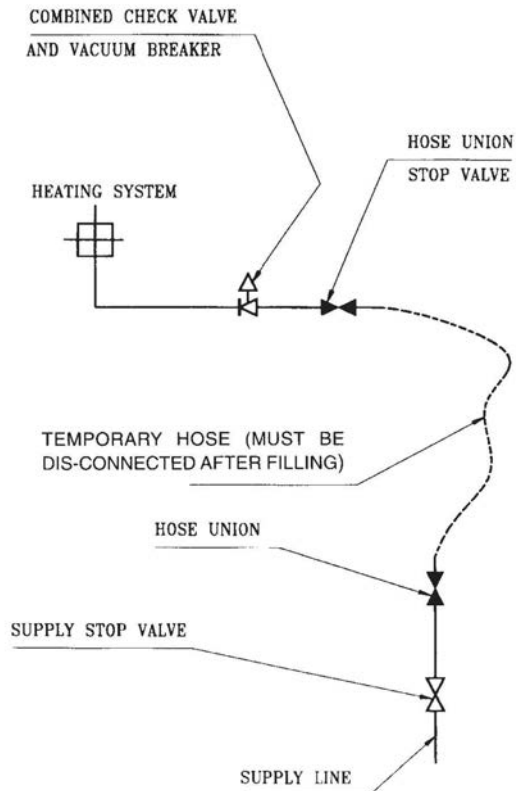


DESN 517996



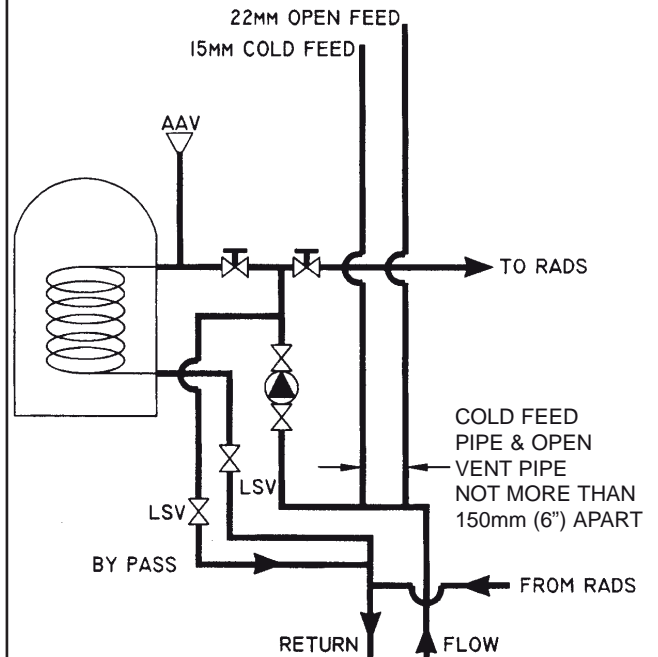
DESN 517997

**Fig. 8.15 PROVISION FOR FILLING SEALED SYSTEM**



DESN 517998

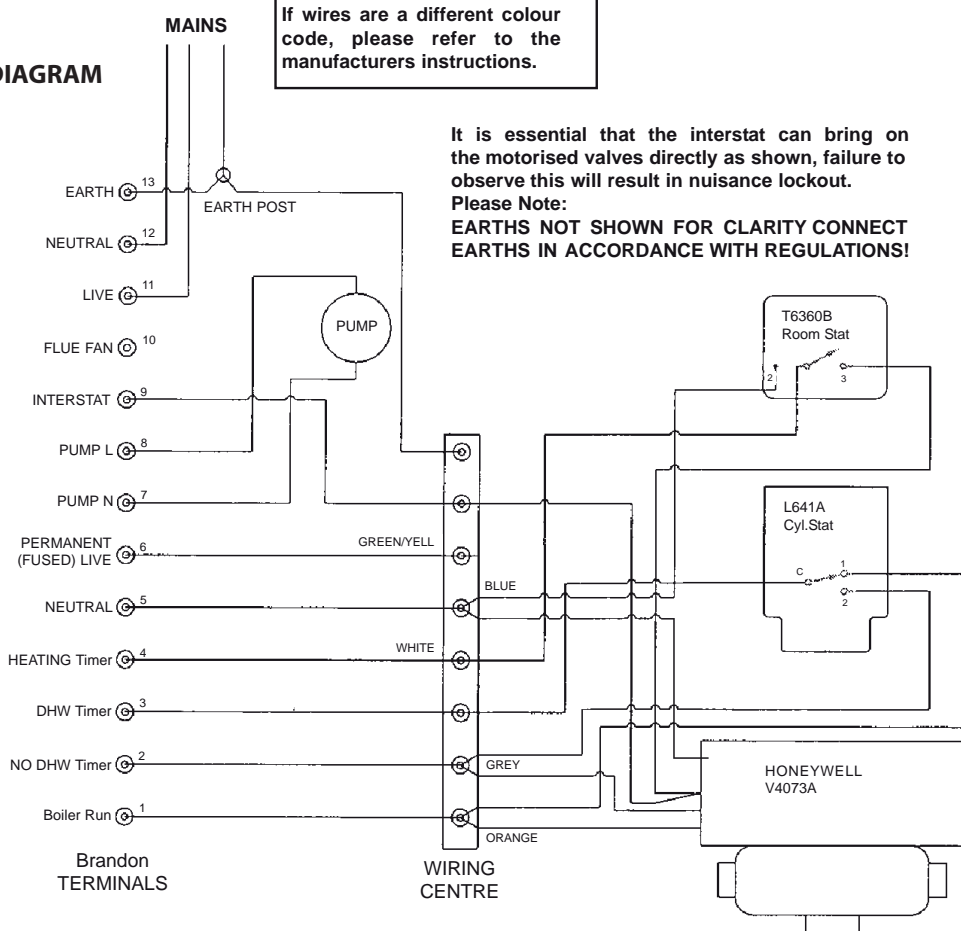
**Fig. 8.17 S PLAN SYSTEM**



DESN 517999

**Fig. 8.16 Y - PLAN WIRING DIAGRAM**

If wires are a different colour code, please refer to the manufacturers instructions.



It is essential that the interstat can bring on the motorised valves directly as shown, failure to observe this will result in nuisance lockout.  
Please Note:  
EARTHS NOT SHOWN FOR CLARITY CONNECT EARTHS IN ACCORDANCE WITH REGULATIONS!

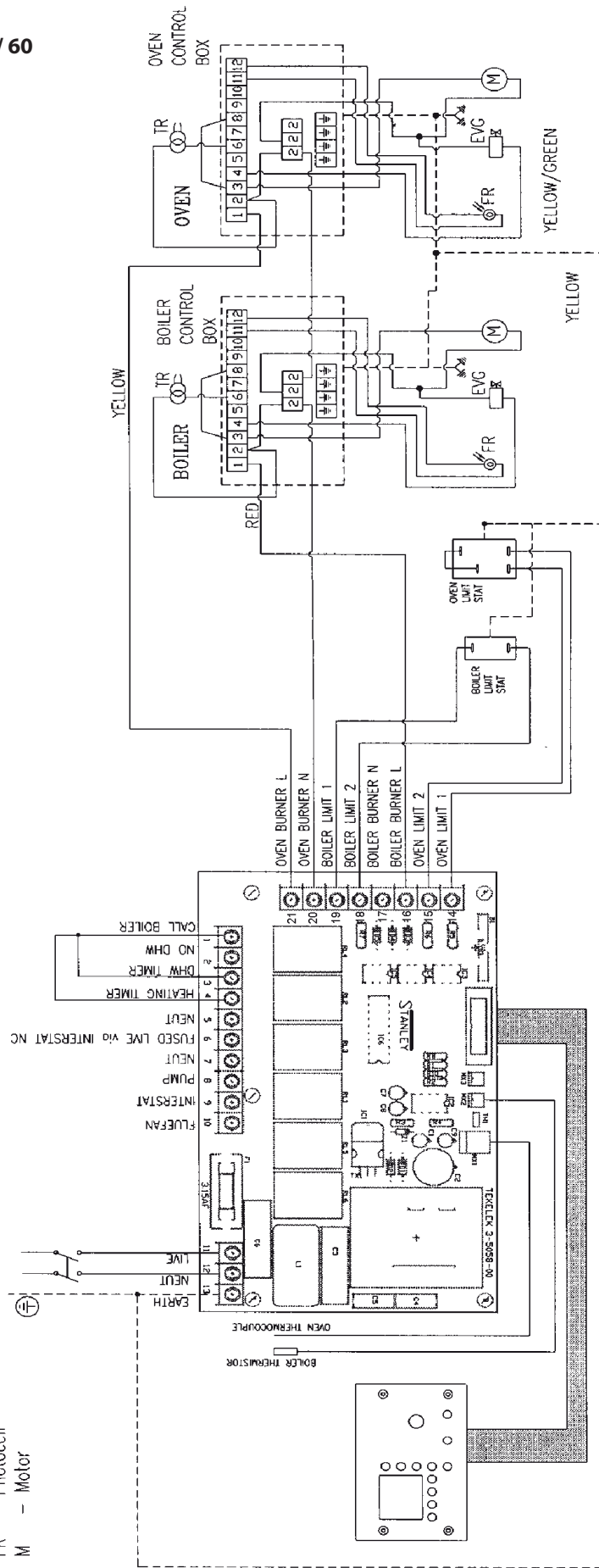
DESN 518000

**Fig. 8.18**

**WIRING DIAGRAM 100 / 80 / 60**

**ELECTRICAL LEGEND**

- TR - Transformer
- EVC - Solenoid Valve
- FR - Photocell
- M - Motor

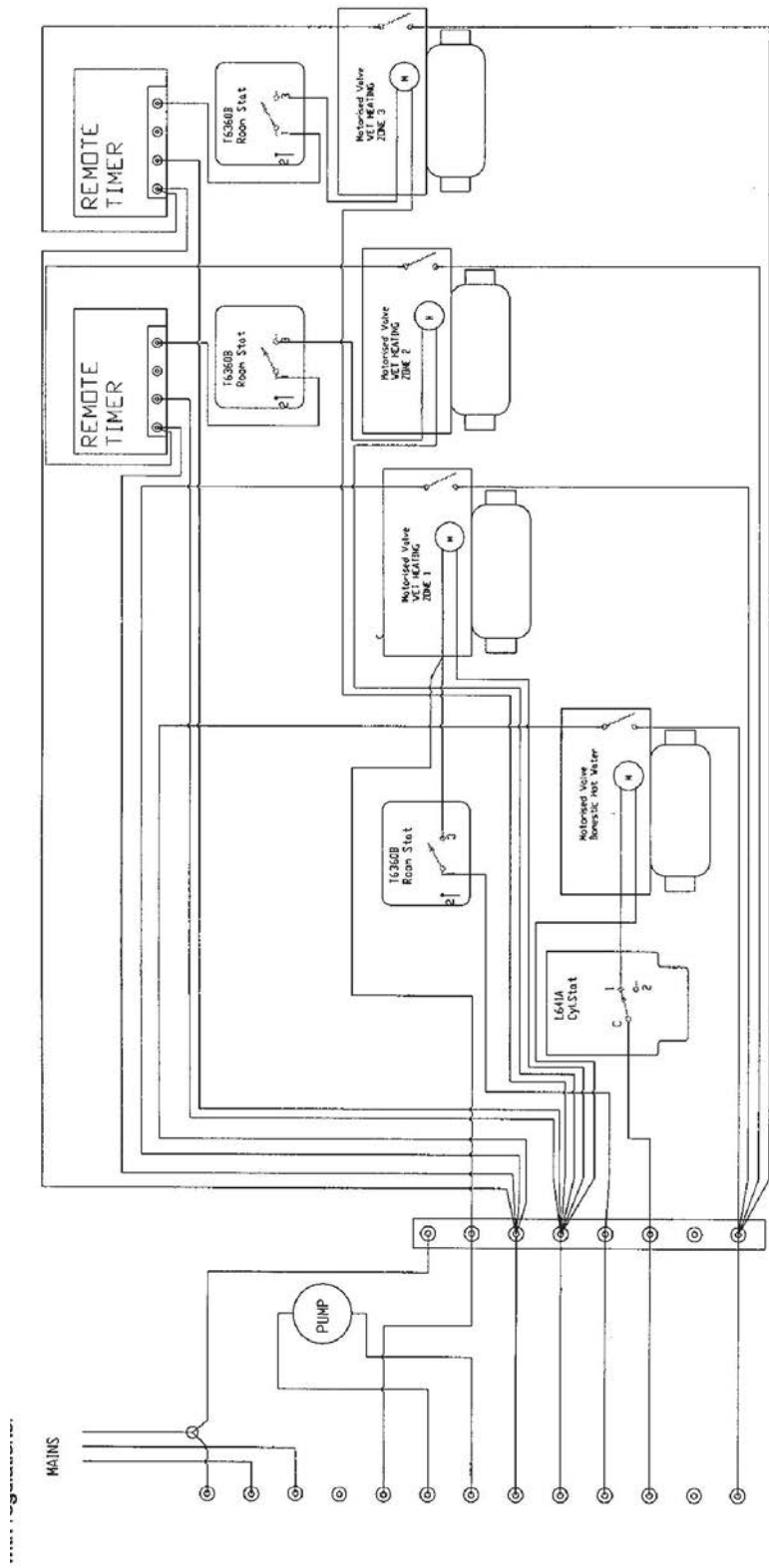


**If wires are a different colour code, please refer to the manufacturers instructions.**

**Fig. 8.19**

**S PLAN WIRING DIAGRAM USING MULTI TIMER FOR ALL CENTRAL HEATING ZONES**

**Note:**  
 It is essential that the interstat can bring on one of the motorised valves directly as shown, failure to observe this will result in nuisance lockout.  
 Please Note: EARTHS NOT SHOWN FOR CLARITY CONNECT EARTHS IN ACCORDANCE WITH REGULATIONS!



## 4 ZONE HEATING SYSTEM

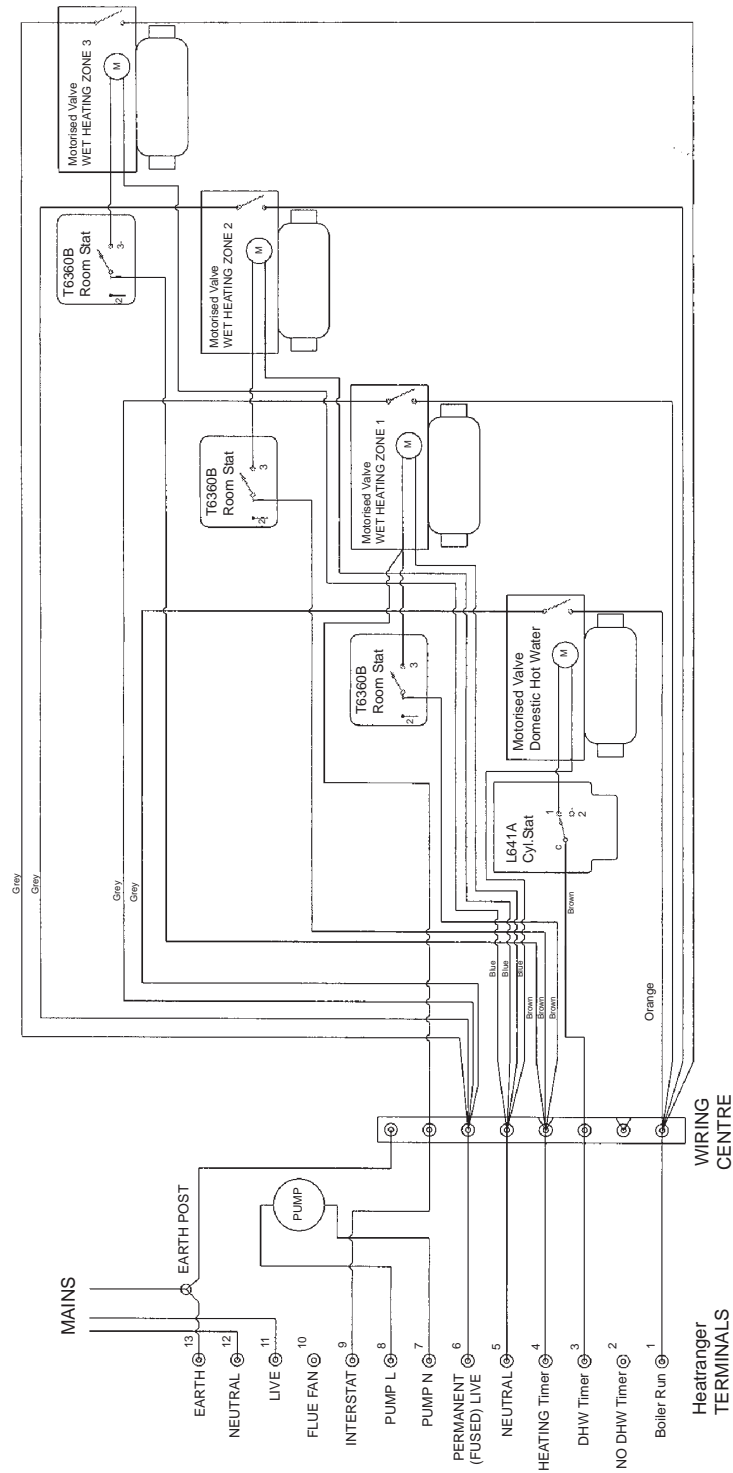
When connecting the Heatranger cooker to a 4 - zoned heating system (i.e. separate time switches and thermostats for domestic hot water and four central heating zones), the domestic hot water and one zone must be controlled directly from the cooker enabling the inter thermostat to operate if necessary. All other zones can be controlled from the cooker where a constant live supply must be connected to the time clocks only (Fig. 8.19).

**Under no circumstances can other supply sources be connected directly to the cooker.**

**Fig. 8.20**

### S PLAN WIRING DIAGRAM USING SAME TIMER FOR ALL CENTRAL HEATING ZONES

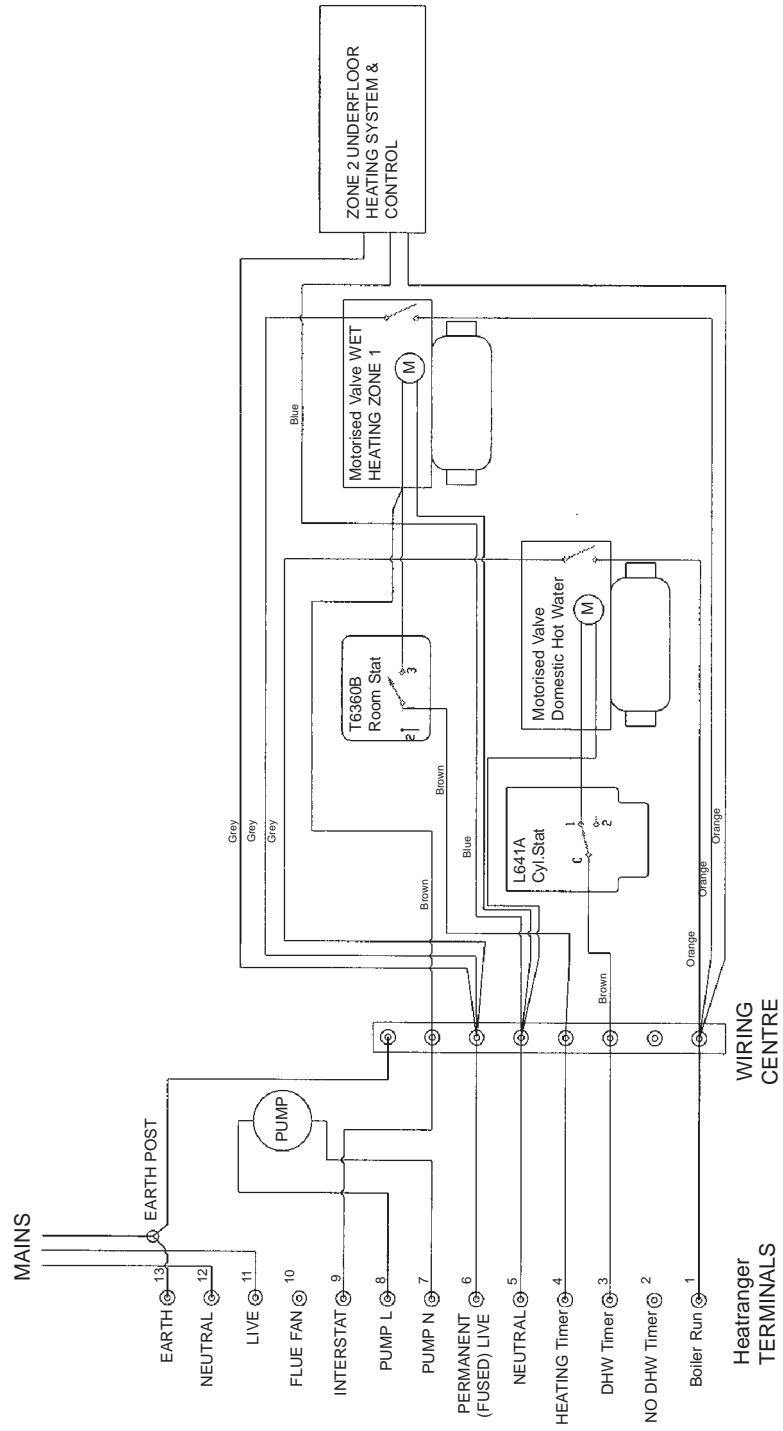
**If wires are a different colour code, please refer to the manufacturers instructions.**



DESN 518003

**Fig. 8.21**

**S PLAN WIRING DIAGRAM SHOWING ZONE CONTROLLED BY UNDERFLOOR HEATING ZONE**



## 9. Fuel Installation

### OIL STORAGE TANKS

Oil storage tanks made of steel and all connecting equipment (eg: filling pipes and vent pipes) should comply with B.S. 799 Part 5. Galvanised steel must not be used. Polyethylene (Plastic) tanks should comply with OFTEC standard OFS T100 and or equivalent. Oil should never be stored in translucent plastic containers.

An isolating valve should be fitted at the tank outlet, in an accessible position so that the oil supply to the appliance can be shut off if required. This isolating valve must be of a type suitable for use with oil. (See **Fig. 9.3, Fig. 9.4, Fig. 9.5 & Fig. 9.6**).

In order to enable the sediment and water to be removed from tanks a drain valve should be fitted. Oil storage tank support must be carried out in accordance with the tank manufactures recommendations. Tanks should be located in the most un-obstructive position possible having taken safety, filling, maintenance and the need, if any, to provide a head of oil for the burner into consideration.

### FUELS

#### THE RECOMMENDED FUEL IS KEROSENE 28 SECOND VISCOSITY FUEL OIL.

#### FUEL SUPPLY LINE

The oil supply line from the oil storage tank to the appliance should be of an approved and suitable pipe with a minimum internal diameter of 9mm ( $\frac{3}{8}$ " ) and connected to the oil inlet connection located at the cooker left hand side.

Oil supply pipes are normally run in annealed copper tube complying to B.S. E.N. 1057. It can be obtained in coil or half hard form for use with bending machines. This pipe can also be obtained with protective plastic sheathing applied. Fittings for copper pipe should be compression of the flared manipulative type to B.S. 864: Part 2 1983. Steel pipes complying with B.S. 1387: 1985, if used, must be protected from corrosion. Galvanised pipe and fittings must not be used.

Screwed joints must only be made with tapered threads complying with B.S. 1740: Part 1: 1971.

Jointing materials must be of types intended for use with oil fuel. Special petroleum – resisting compounds and PTFE tape are suitable. External pipes should preferably be run with a continuous rise towards the direction of flow, so that one can be vented off. It is important to avoid high points which could cause air locks.

Exposed lengths of oil supply pipe must be properly supported by purpose made clips securely fixed in place. Metal clips formed so as to hold the pipe on to a saddle are preferred. Consideration should be given to avoiding routes which expose the pipe to severe chilling which could cause freezing of the oil. Where pipes are buried, they must be protected from accidental damage. The use of joints

underground should be avoided if at all possible. If joints have to be fitted in pipes laid below ground, access to them must be provided.

An oil filter (5 - 10 micron) and stop valve must be fitted to the fuel feed line and located near the supply tank and facilities should be provided to enable it to be serviced without draining down the oil supply system. (See **Fig. 9.3, Fig. 9.4, Fig. 9.5 & Fig. 9.6**).

At the point where the oil line enters the building, the oil line must be fitted with an approved 65°C remote acting fire valve, which meets the requirements of B.S. 5410: Part 1, fitted with the appropriate length of capillary. The heat sensor phial of the fire valve must be fitted to the clip provided in the burner compartment. It is absolutely essential that the fire valve is located externally and is as close as possible to the appliance. For existing installations where the oil supply are built into the structure internally, the remote acting fire valve should be fitted where the oil supply line is first exposed internally. This type of layout is not recommended for new installations.

When gravity feed is used (the most common) the minimum head should not be below 1 meter (3'3") and the maximum head should not exceed 6.5 meters (21'3").

**NOTE:** The pump is factory set for a single pipe installation to convert to a two pipe system consult manufacturer's instructions.

Before connecting the oil supply, secure appliance burner oil pipes to the base using the T junction (see **Fig. 9.1 & Fig. 9.2**).

#### SINGLE PIPE SUPPLY SYSTEM: BOTTOM OF OIL STORAGE TANK ABOVE BURNER (See Fig. 9.3)

Single pipe supply system: Tanks servicing this appliance by means of a single pipe need to be positioned so that they will apply the minimum head required 1 meter (3'3") of oil to the burner when the fuel level is at its lowest point.

Refer to B.S. 5410 to calculate the additional head requirement relating to pipe length and size.

#### TWO PIPE SUPPLY SYSTEM: BOTTOM OF OIL STORAGE TANK BELOW OR LEVEL WITH BURNER (see Fig. 9.4)

If the tank base is below the level at which the gravity feed to the burner can be maintained, a two pipe oil supply system may be adopted. (See **Fig. 9.4**). The non-return valve in the supply line of the two pipe system is required to prevent oil running back from the burner and unpriming the oil pump. The non-return valve in the return line is only required if the top of the tank is above the burner. Its purpose is to prevent oil running back through the burner during maintenance.

#### SINGLE PIPE SYSTEM: WITH DE-AERATION DEVICE BOTTOM OF OIL STORAGE TANK BELOW OR LEVEL WITH BURNER. (see Fig. 9.5):

This system can be used where the tank base is below the level at which gravity feed to the burner can be maintained and the burner incorporates an oil pump. The chamber is

fitted close to the burner and is linked to the tank by a single pipe, thus saving the return pipe required by the two pipe system as described previously. Any air in the oil brought up from the tank is bled off in the de-aeration chamber.

De-aeration chambers must always be installed externally to buildings because they emit small quantities of vapour. The chamber is connected to the oil pump in the burner of the appliance by a normal two pipe loop.

### TIGER LOOP OIL SUPPLY (see Fig. 9.6)

For installations normally requiring a two pipe system but have long or difficult return line runs, an alternative Tigerloop Deaerator system can be used. Tigerloop Deaerators remove air from a two pipe oil feed. Higher lift heights can be achieved than are possible with a conventional two pipe system.

These requirements are fully explained within the following documents:

- B.S. 5410: Part 1: Code of Practice for Oil firing installations up to 45 kW output capacity for space heating and hot water supply purposes.
- OFTEC - Technical Information Book Three. Installation requirements for oil fired boiler and oil storage tanks.
- The Building Regulations Part J: Ireland Part F Section 4 Scotland and Part L Northern Ireland.
- The Building Regulations Part J: England & Wales.

### INSTALLATION CHECK LIST

1. Check all items from packaging are removed from ovens and the shelves are properly fitted.
2. Check that electrical wiring is correct.
3. Check that the boiler and heating system is full of water and purged of air.
4. Check that the boiler plate transport screws have been removed and that the plates are in their correct positions. (See section removal of transport screw and Fig. 9.12)
5. Time switches and room thermostats must be on.
6. Check that all valves in the oil line are open and that the filter is purged of air. Check that the fire valve is open.
7. Turn on the electrical supply and check that any time switches are on and room thermostats associated with the cooker are on and calling for heat. Burners should now fire.
8. Check that the interstat connection has been wired directly to a motorised valve. This is done by turning off room thermostats, time switches and temporarily linking terminals 6 & 9. This should bring on a motorised valve which will then call the boiler. Note: When the interstat calls; normally the motorised valve will open, but the burner will not operate as the supply to No.6 will be disabled.

9. Check temperature differential between flow and return 11°C (20°F) and adjust pump or bypass accordingly.
10. Check heating circuit and balance if necessary.
11. With fuel supply off, switch on the burners.
12. Complete the start sequence to lockout (8 seconds) for both burners observing the correct operating functions.
13. Ensure both pumps are purged of air. Check pump pressure with a calibrated pressure gauge and adjust it as necessary. (See Fig. 9.7 & Fig. 9.8) For further information refer to 100, 80 and 60 specification on page 18.
14. Re-instate fuel supply and switch on the burners to ensure that they fire correctly.
15. After the appliance has achieved its operating temperature, with each burner running, carry out a flue gas analysis for each burner. (See Fig. 9.9).
16. Check for smoke and flue draught reading.
17. Check and set combustion approximate settings:

Boiler		Cooker	
Air Setting	CO <sup>2</sup> %	Air Setting	CO <sup>2</sup> %
9	11.5	5	10
8	11.8	4	10.34
7	11.9	3	10.8
6	12.2	2	11.2

18. Find the correct position of the air control, which gives the highest reading of CO<sup>2</sup> within the range of the table above without exceeding a smoke No. 0-1 (Bacharach Scale). (See Fig. 9.10 & Fig. 9.11)
19. Check the oil supply for leaks from storage tanks via oil filter.
20. Check if complete system is working correctly.
21. Make sure specified clearances are adhered to.
22. Check flue joints are sealed correctly and that no escapes are present.
23. If not satisfied check the trouble shooting guide.
24. After withdrawing the mains cable tighten the anti-tug gland located at the left side of the cooker base level.
25. Refer to the Operation Instructions Manual for correct operation of the appliance and familiarise the occupants on the correct method of operating the appliance.  
**LEAVE ALL DOCUMENTS WITH THE END USER.**
26. Check lockout (8 seconds)
  - a. Check cooker burner is purged of air, check cooker burner with a calibrated pressure gauge and adjust if necessary to 110 p.s.i.
  - b. To complete commissioning exercise refer back to point number 14.



## REMOVAL OF TRANSPORT SCREW/S

Remove the hotplate and boiler top plate. Remove retaining screws from boiler plates. Check that all plates have remained in their correct position and that no debris has accumulated on them during transport. Replace boiler top plate and hotplate ensuring that all seals are intact (See Fig. 9.12).

## FUNCTION

### Normal Start

Pre-ignition and pre-purging, after 7 seconds oil released, and the burner operates, if the flame forms within the safety time of 10 seconds.

**Post ignition after oil release:** LOA 24 - 10 seconds.

### False light at start

If oil is released and no flame is established the control will cut out within the safety time of 10 seconds.

### Flame failure in operation

In the event of flame failure in operation the oil supply is cut off and the control restarts the burner as described under the heading "Normal Start". On flame failure, immediately after burner start, the control will initiate re-ignition.

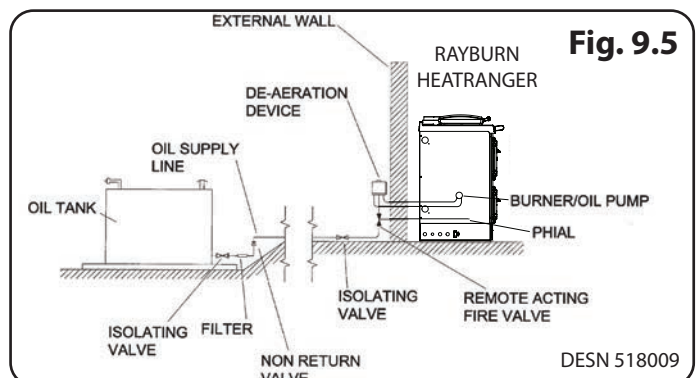
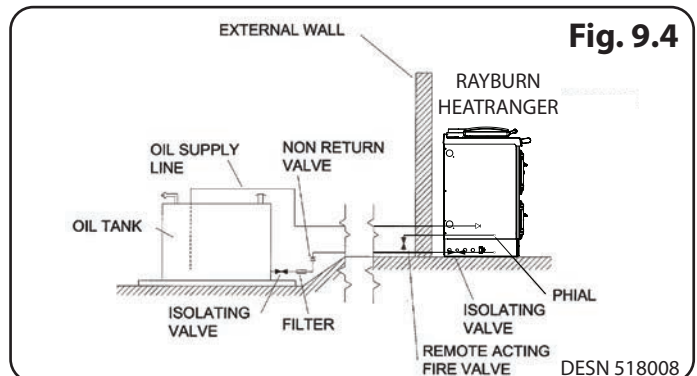
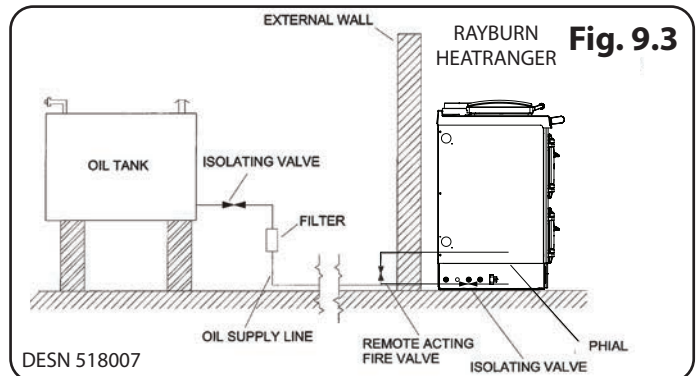
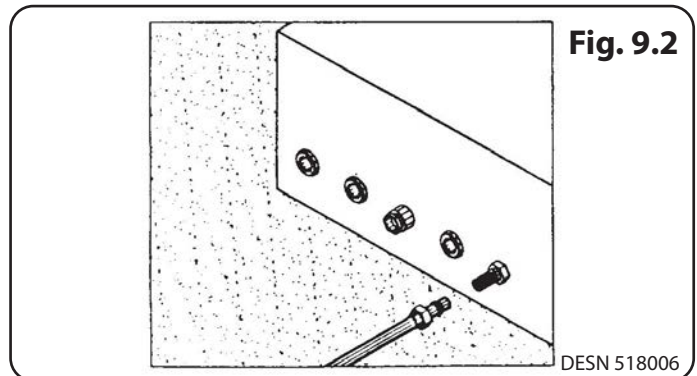
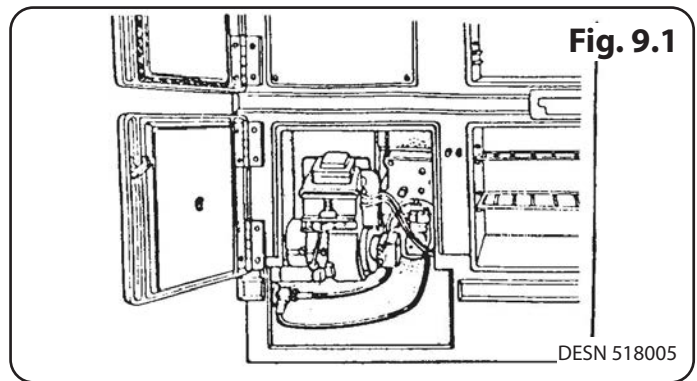
### Flame monitoring

The flame is monitored by a photocell unit. Note: In accordance with the latest ISO and DIN standards, type LOA activates the safety relay if the photocell unit is exposed to light in the pre-purging period.

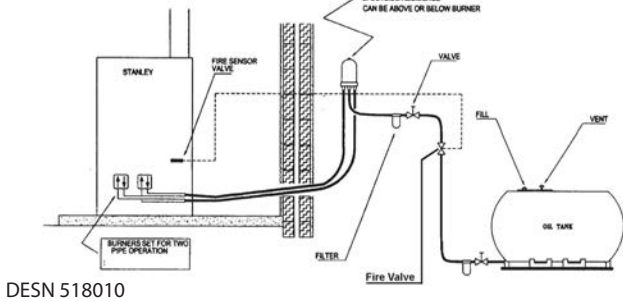
### Control of flame signal

The photocell current is measured with a d.c. ammeter (moving coil instrument) which is connected in series with the photocell unit. Min current for flame indication: 35  $\mu$ A.

**! IMPORTANT NOTE:** Once you are satisfied that the cooker is properly installed in accordance with these instructions, you must turn off the cooker which should not be re-lighted until it has been commissioned by an accredited Commissioning Agent.

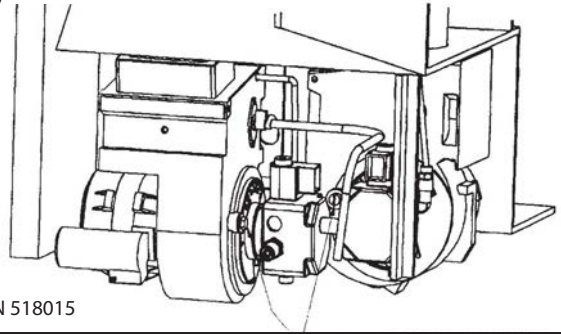


**Fig. 9.6**



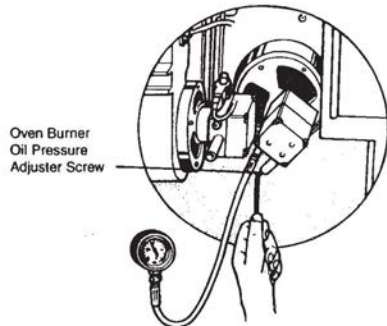
DESN 518010

**Fig. 9.11**



DESN 518015

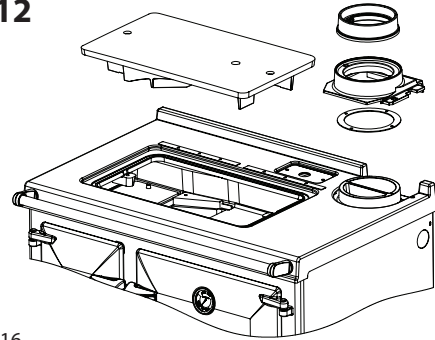
**Fig. 9.7**



DESN 518011

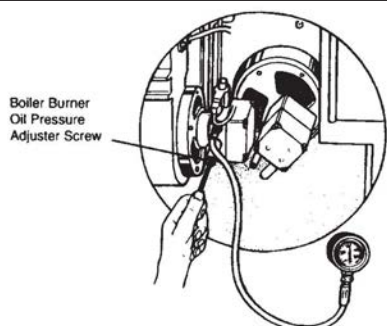
**Cooker Pressure Settings**

**Fig. 9.12**



DESN 518016

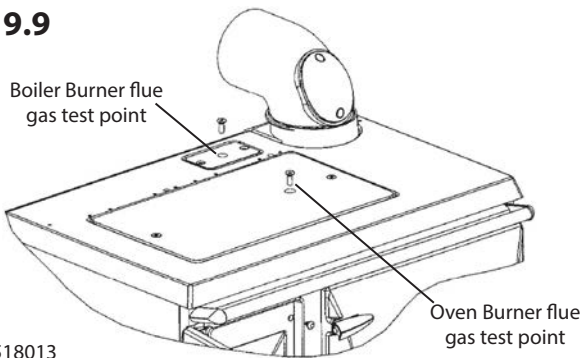
**Fig. 9.8**



DESN 518011

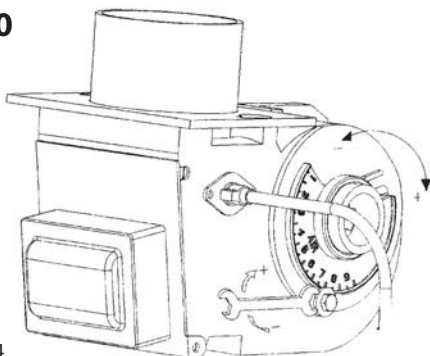
**Boiler Pressure Settings**

**Fig. 9.9**



DESN 518013

**Fig. 9.10**



DESN 518014

# 10. Installation Checklist

## Flue System

The relevant guidelines must be adhered to for the relevant flue system A, B & C:

A. Use of an Existing Chimney		
1.	If connecting to an existing chimney, the appliance should be connected to a 150mm (6") diameter continuous, rigid or flexible flue pipe suitable for oil-fired appliances that terminates in excess of 0.6 metres from the nearest point on the roof measured vertically, and in excess of 2.3 metres measured horizontally.	<input type="checkbox"/>
2.	Minimum Flue Height of 4.6 metres (15 feet).	<input type="checkbox"/>
3.	Any horizontal flue sections should not exceed 450mm (18").	<input type="checkbox"/>
4.	The chimney serving this appliance should not serve any other appliance.	<input type="checkbox"/>
5.	A suitable flue terminal should be fitted at the flue termination point.	<input type="checkbox"/>
6.	Closure-clamping plates should be used to seal the top & bottom of the chimney.	<input type="checkbox"/>
7.	If the flue passes through a combustible wall, a twin wall insulated connector must be used and come flush to the external surface of the wall.	<input type="checkbox"/>
8.	The flue should be capable of producing a continuous draught of between 0.04" to 0.06" w.g.	<input type="checkbox"/>
B. Use of an External Flue		
1.	If using an external flue, the appliance should be connected to a 150mm (6") diameter rigid insulated flue pipe suitable for oil-fired appliances that terminates in excess of 0.6 metres from the nearest point on the roof measured vertically and in excess of 2.3 metres measured horizontally.	<input type="checkbox"/>
2.	Minimum Flue Height of 4.6 metres (15 feet).	<input type="checkbox"/>
3.	Any horizontal flue sections should not exceed 450mm (18").	<input type="checkbox"/>
4.	The chimney serving this appliance should not serve any other appliance.	<input type="checkbox"/>
5.	A suitable flue terminal should be fitted at the flue termination point.	<input type="checkbox"/>
6.	The flue should be capable of producing a continuous draught of between 0.04" to 0.06" w.g.	<input type="checkbox"/>
Location		
1.	The cooker should be installed on a non-combustible material capable of supporting the weight of the unit.	<input type="checkbox"/>
2.	The cooker should be positioned so as to maintain a 10mm gap between the cooker and the adjacent kitchen units.	<input type="checkbox"/>
Plumbing		
1.	A three bar safety valve must be fitted to the primary flow pipe adjacent to the boiler connection on the stove.	<input type="checkbox"/>
2.	The cooker must be connected to a fully pumped system using 28mm flow & return supply pipes.	<input type="checkbox"/>
3.	A 15mm system by-pass must be fitted not less than 1.5 metres from the cooker.	<input type="checkbox"/>
4.	Hot supply to the central heating system should be controlled using a motorised valve with live supply to valve provided by the relevant connection on the cooker control board.	<input type="checkbox"/>
Ventilation & Combustion Air Requirements		
1.	The room in which the appliance is located should have an air vent of adequate size to support correct combustion when all air-using appliances are working at full capacity (See Ventilation & Combustion Air Requirement Section for specific details).	<input type="checkbox"/>
Oil Supply		
1.	The oil supply tank should be fitted with an insulating valve and filter.	<input type="checkbox"/>
2.	The stove should be connected to a supply line with a minimum internal diameter of 10mm (3/8") and must be fitted with a remote acting fire valve.	<input type="checkbox"/>
3.	If a single pipe oil supply system is used, a minimum head of oil of 1 meter must be maintained (see Fuel Installation Section).	<input type="checkbox"/>

For further advice or information contact your  
local Rayburn Specialist.

With AGA Rangemaster's policy of continuous product  
improvement, the Company reserves the right to change  
specifications and make modifications to the appliances  
described and illustrated at any time.



Manufactured By  
AGA Rangemaster  
Station Road, Ketley Telford  
Shropshire TF1 5AQ. England

[www.agaliving.com](http://www.agaliving.com)  
[www.agacookshop.co.uk](http://www.agacookshop.co.uk)

